

101D Vacuum Tube

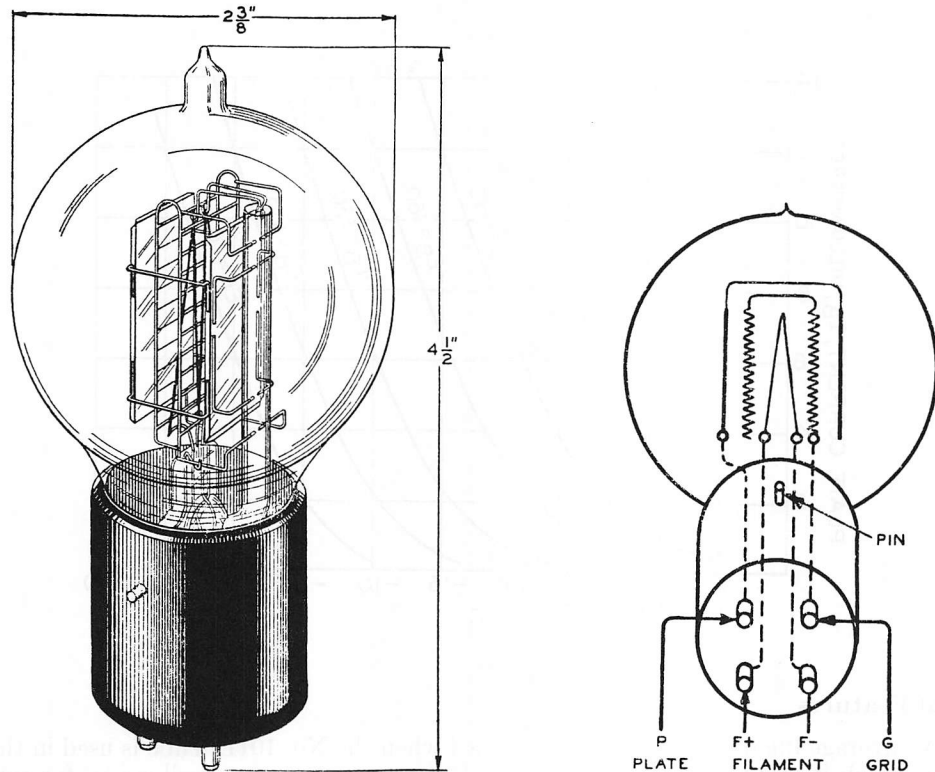

Classification

The No. 101D Vacuum Tube is a three-element filamentary type tube for use where small amounts of output power are required.

Base and Socket

The No. 101D Vacuum Tube employs a four-prong bayonet pin type base suitable for use in a Western Electric 100L (front panel mounting), 100R (rear panel mounting), or similar type socket.

Rating and Characteristic Data

| | | | | |
|---|-------------|-------|-------|----------|
| Filament Current..... | 1.0 Amperes | | | |
| Filament Voltage..... | 4.5 Volts | | | |
| Plate Voltage..... | 130 | 130 | 160 | 190 Max. |
| Grid Voltage..... | -9 | -9 | -14 | -18 |
| Average Plate Current—Milliamperes..... | 7.4 | 7.4 | 7.35 | 8.35 |
| Average Amplification Factor..... | 6.0 | 6.0 | 6.0 | 5.95 |
| Average Plate Resistance—Ohms..... | 5700 | 5700 | 5800 | 5600 |
| *Average Power Output—Milliwatts..... | 65 | 60 | 135 | 230 |
| Second Harmonic—% of Fundamental..... | 5 | 3 | 4 | 5 |
| Third Harmonic—% of Fundamental..... | 0.4 | 0.2 | 0.4 | 0.5 |
| Load Resistance—Ohms..... | 5700 | 11400 | 11600 | 11200 |

*Input in peak values is equal to grid voltage.

Approximate Direct Interelectrode Capacities (measured without socket)

| | |
|------------------------|---------|
| Plate to Grid..... | 5.0 MMF |
| Plate to Filament..... | 2.0 MMF |
| Grid to Filament..... | 3.7 MMF |

Average Static Characteristics

The accompanying curves give the average static characteristics of the No. 101D Vacuum Tube.

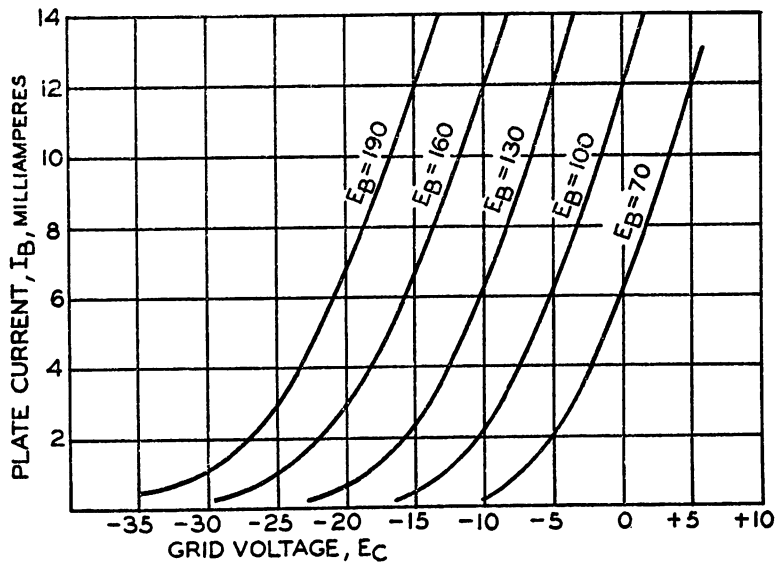

General Features

An average life of 40,000 hours is obtained when the No. 101D Tube is used in the equipment for which it was designed. This long life feature makes it very well suited for continuous operation where long uninterrupted service is desired.

The electrical characteristics for this tube are such that moderate power outputs are obtainable with small plate currents and with plate voltages under 200 volts. The characteristics of the No. 101D Tube are similar to those of the No. 101F, however, the No. 101D operates at a filament current of 1.0 ampere instead of 0.5 ampere.

Western Electric

101D Vacuum Tube (Dome)

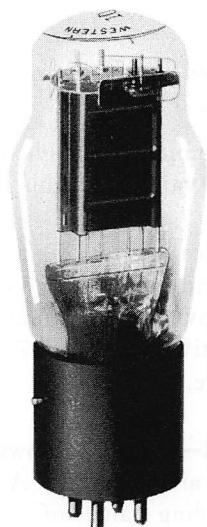

Classification—Low-Power, Filamentary Triode

This tube replaces the D-86326 tube and has been assigned the old code number 101D. It includes an improved filament, a new mechanical design using transverse mica supports and is mounted in a dome type bulb. The electrical characteristics are essentially the same as for the D-86326 tube.

Applications—Voice frequency and carrier-frequency amplifier for telephone repeater equipment and other applications where small power outputs are required.

Modulator and demodulator in carrier-systems.

Oscillator in voice and carrier frequency applications.

Dimensions and Connections—Figures 1 and 2 show the outline diagrams of the tube and base, giving the dimensions and the arrangement of the electrode connections to the base terminals.

Base and Mounting—This vacuum tube employs a medium, four-pin bayonet type base having special contact metal at the ends of the pins. It is suitable for use in a Western Electric 100L, 100R, or similar type socket, preferably provided with contact-metal contacts.

The tube may be mounted in either a vertical or horizontal position. If mounted in a horizontal position the plane of the filament, which is indicated in Figure 2, should be vertical. To assure adequate ventilation the tubes should be mounted with not less than $2\frac{5}{8}$ inches between centers when two or more tubes are used.

Average Direct Interelectrode Capacitances

| | |
|------------------------|----------------------|
| Grid to Plate..... | 6.4 $\mu\mu\text{f}$ |
| Grid to Filament..... | 4.4 $\mu\mu\text{f}$ |
| Plate to Filament..... | 2.9 $\mu\mu\text{f}$ |

These values are for a based tube without socket.

Filament Rating

| | |
|-------------------------------|------------------|
| Filament Current..... | 1.0 ampere, d.c. |
| Nominal filament voltage..... | 4.5 volts |

The filament of this tube is designed to operate on a current basis and should be operated at as near the rated current as practicable.

The filament resistance of this tube increases slightly during the first 2000 hours of operation. The voltage given above is the nominal value after this resistance change has stabilized.

Characteristics—Figure 3 shows typical curves of plate current as a function of grid voltage for several values of plate voltage. The grid and plate voltages are measured from the negative end of the filament. Figures 4, 5 and 6 show corresponding amplification factor, plate resistance and transconductance characteristics respectively. Figure 7 shows plate current as a function of plate voltage for several values of grid voltage.

Operating Conditions and Output—Figure 3 shows the range of permissible operating plate and grid voltages included within the area ABCD. A number of recommended and maximum operating conditions and the corresponding values of amplification factor, plate resistance, transconductance and performance data are given in the table.

Recommended conditions or others of no greater severity should be selected in preference to maximum conditions wherever possible. The life of the tube at maximum operating conditions will be shorter than at less severe conditions.

The performance data shown include the fundamental power output in milliwatts and the second and third harmonic levels in db below the fundamental for values of load resistance equal to the plate resistance and for a load resistance of 12000 ohms. The peak value of the sinusoidal input voltage E_{gm} , which gives the indicated output P_m , and harmonic levels F_{2m} , and F_{3m} , in each case is numerically equal to the grid bias. For a smaller input voltage E_g , the approximate levels may be computed from the following relations:

$$P = P_m \left(\frac{E_g}{E_{gm}} \right)^2$$

$$F_2 = F_{2m} + 20 \log_{10} \frac{E_{gm}}{E_g}$$

$$F_3 = F_{3m} + 40 \log_{10} \frac{E_{gm}}{E_g}$$

Microphonic Noise

For a plate voltage of 130 volts, a grid bias of -9 volts, and a load resistance of 100,000 ohms, the mean microphonic output level of this tube, measured in a laboratory reference test set is 32 db below 1 volt. The range of levels of individual tubes extends from 20 to 40 db below 1 volt. Since microphonic noise output depends on the type and intensity of the mechanical disturbance which produces it, the values given here are useful chiefly for comparison with the levels of other types of tubes which have been tested in the same way.

TABLE

| | <u>Plate Voltage</u> Volts | <u>Grid Bias</u> Volts | <u>Plate Current</u> Milli-amperes | <u>Amplification Factor</u> | <u>Plate Resistance</u> Ohms | <u>Trans-conductance</u> Micro-mhos | <u>Load Resistance</u> Ohms | <u>Power Output</u> Milli-watts | <u>Second Harmonic</u> db | <u>Third Harmonic</u> db |
|----------------------------------|-------------------------------|---------------------------|---------------------------------------|-----------------------------|---------------------------------|--|--------------------------------|------------------------------------|------------------------------|-----------------------------|
| Recommended Operating Conditions | 100 | -4 | 8.1 | 6.2 | 5700 | 1090 | 5700 | 14 | 38 | 61 |
| | | | | | | | 12000 | 12 | 45 | 73 |
| | 130 | -12 | 4.7 | 6.2 | 6800 | 900 | 6800 | 91 | 22 | 35 |
| | | | | | | | 12000 | 89 | 28 | 44 |
| | 130 | -9 | 7.7 | 6.2 | 5800 | 1070 | 5800 | 65 | 31 | 48 |
| | | | | | | | 12000 | 58 | 37 | 57 |
| 130 | -6 | 11.2 | 6.2 | 5100 | 1220 | 5100 | 34 | 38 | 60 | |
| | | | | | | 12000 | 29 | 45 | 68 | |
| 160 | -16 | 5.6 | 6.1 | 6500 | 940 | 6500 | 172 | 20 | 32 | |
| | | | | | | 12000 | 161 | 27 | 40 | |
| 160 | -12 | 9.9 | 6.2 | 5300 | 1170 | 5300 | 121 | 29 | 46 | |
| | | | | | | 12000 | 108 | 37 | 56 | |
| Maximum Operating Conditions | 160 | -10 | 12.5 | 6.2 | 4900 | 1270 | 4900 | 93 | 33 | 53 |
| | | | | | | | 12000 | 79 | 41 | 64 |
| | 190 | -20 | 6.4 | 6.1 | 6200 | 990 | 6200 | 263 | 19 | 30 |
| | | | | | | | 12000 | 250 | 26 | 37 |
| 190 | -18 | 8.7 | 6.2 | 5600 | 1100 | 5600 | 248 | 23 | 35 | |
| | | | | | | 12000 | 224 | 31 | 46 | |
| 190 | -16 | 11.0 | 6.2 | 5100 | 1210 | 5100 | 223 | 26 | 42 | |
| | | | | | | 12000 | 187 | 35 | 54 | |

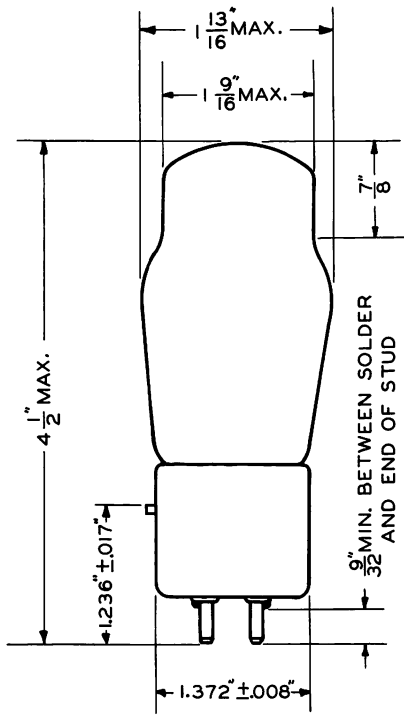

FIG. 1

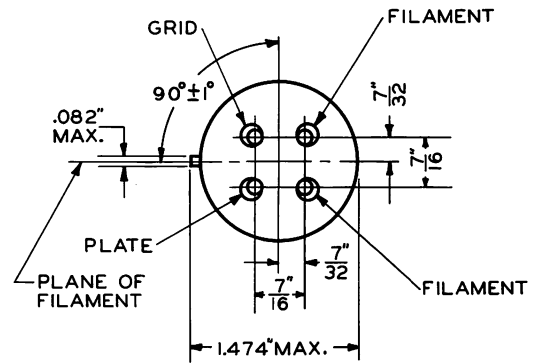

FIG. 2

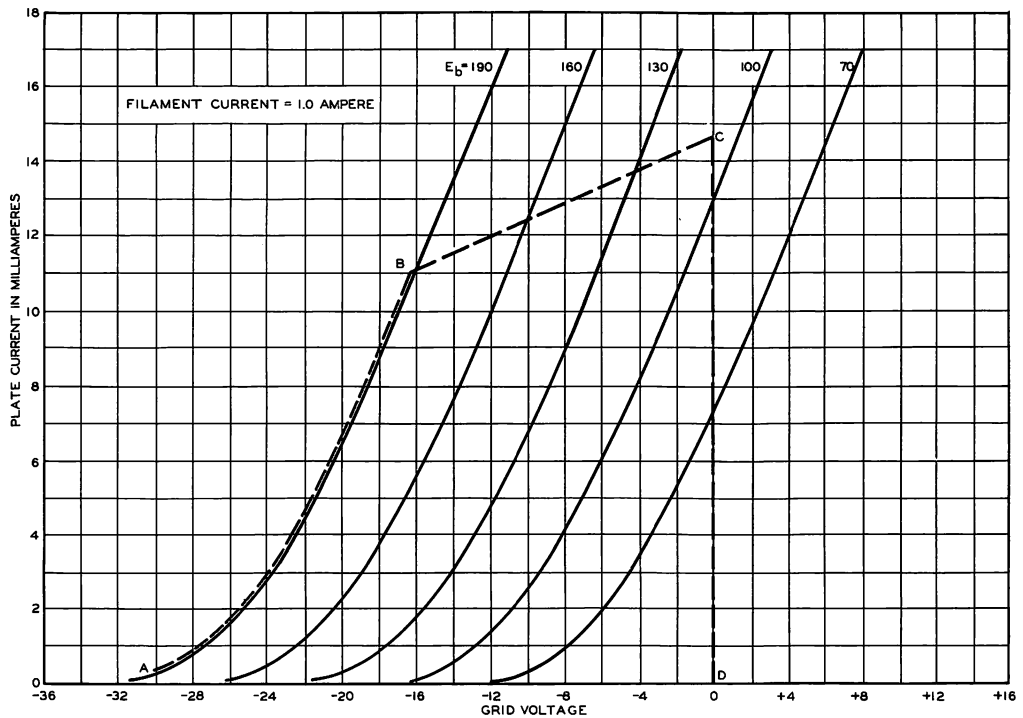

FIG. 3

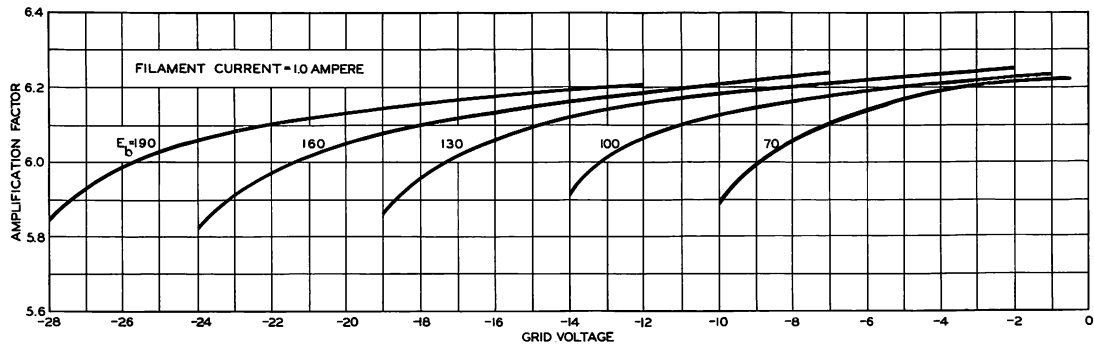

FIG. 4

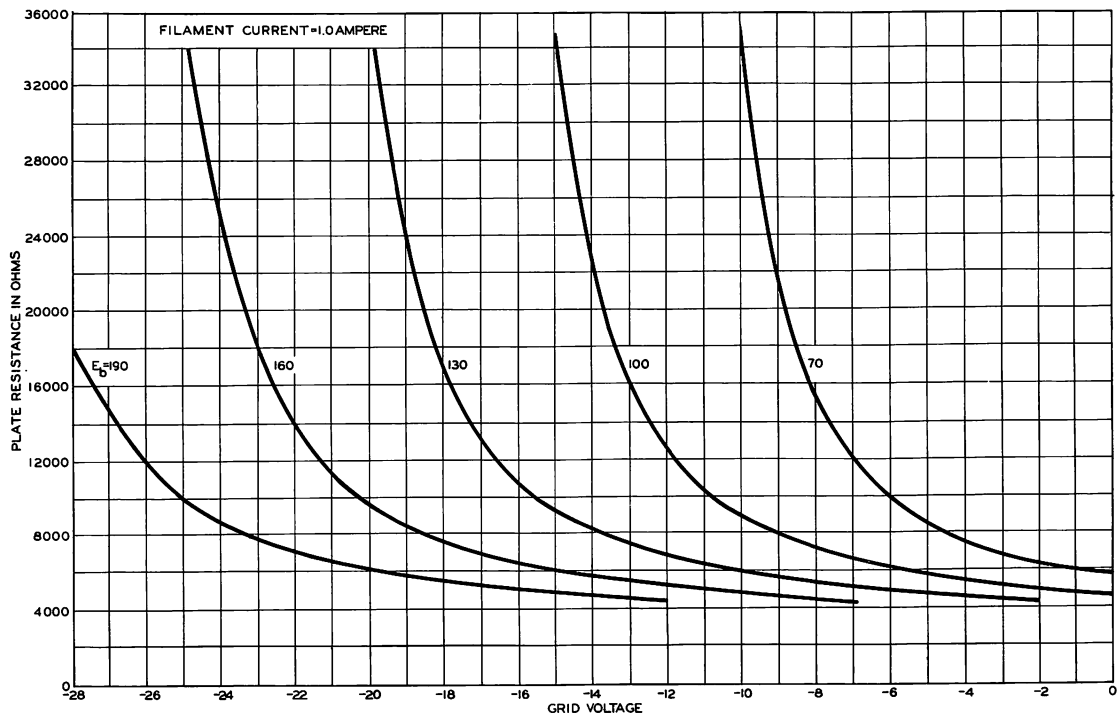

FIG. 5

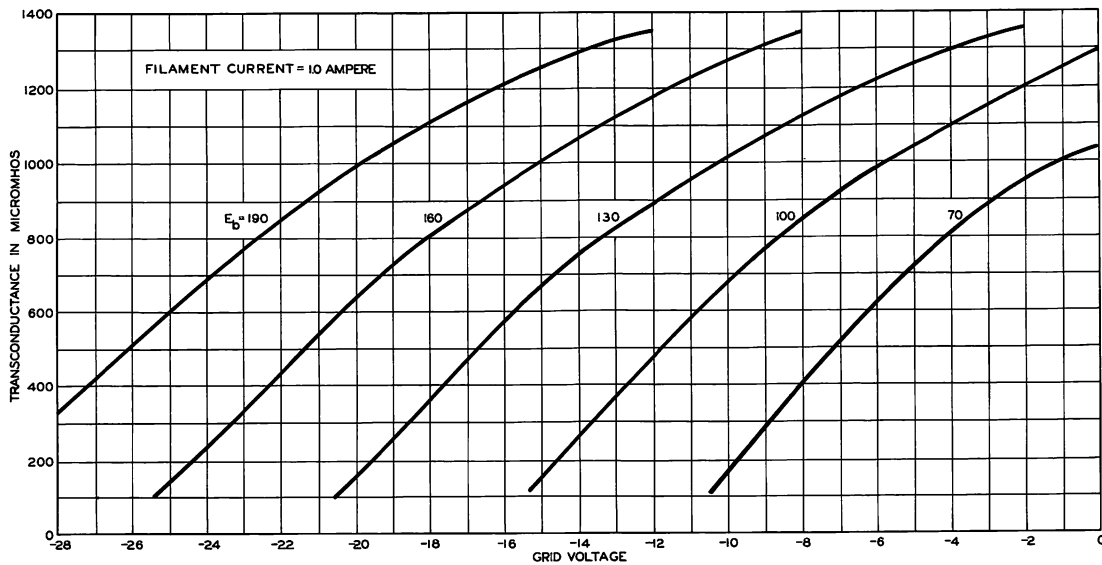

FIG. 6

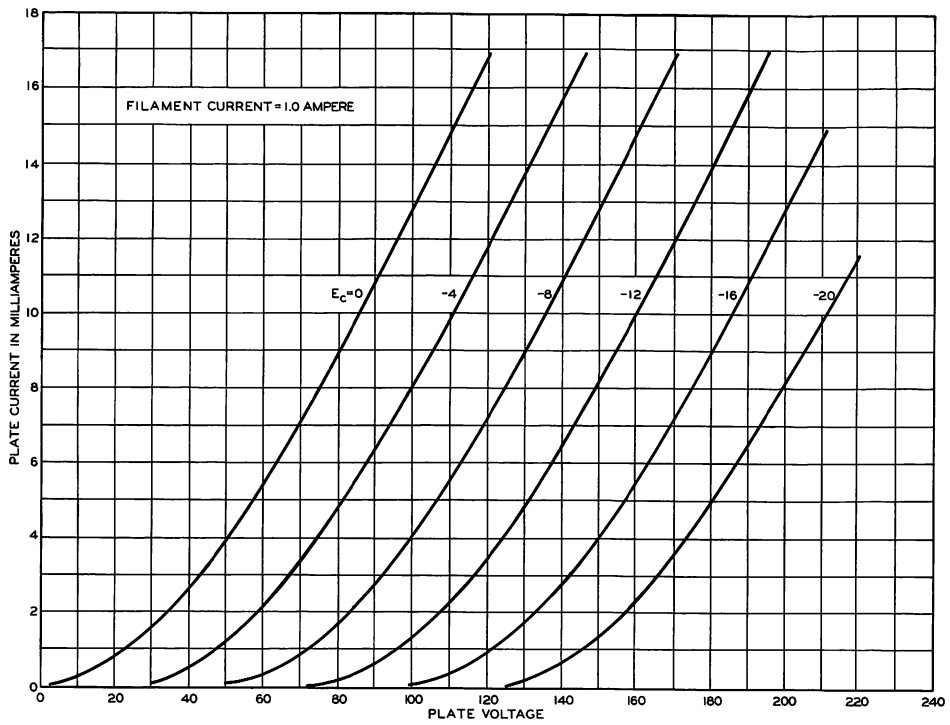

FIG. 7