

## 102F Vacuum Tube

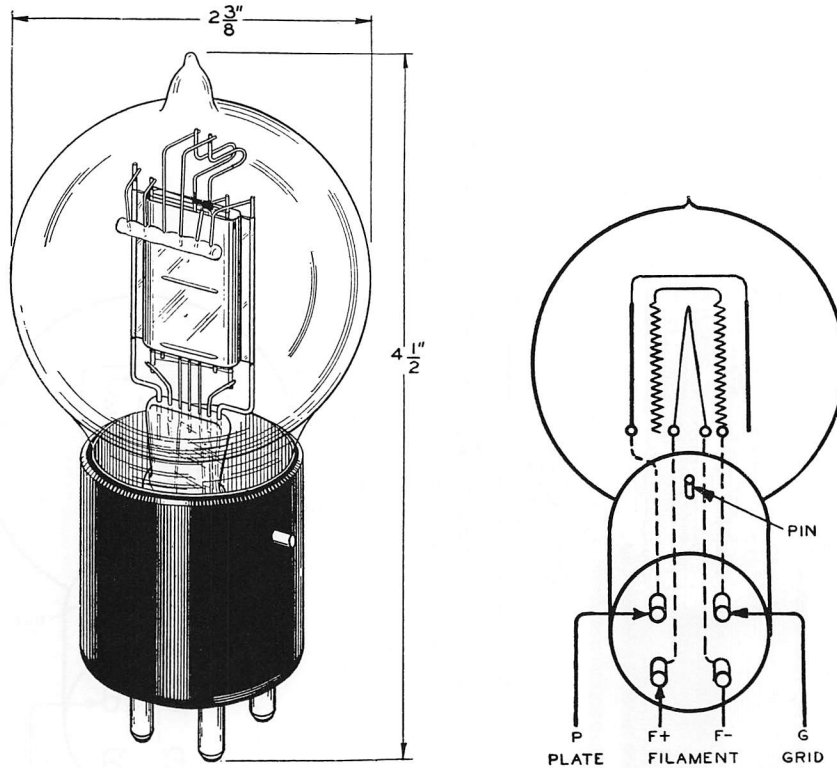

### Classification

The No. 102F Tube is a three element filamentary type vacuum tube primarily intended for use as a voltage amplifier. It may also be used as a modulator, detector, or in volume indicator circuits.

### Base and Socket

The No. 102F Vacuum Tube employs a four prong bayonet pin type base suitable for use in the Western Electric 100L (front panel mounting), 100R (rear panel mounting), or similar type socket.

### Rating and Characteristic Data

Filament Current.....				0.5 Ampere
Filament Voltage.....				2.1 Volts
Plate Voltage.....	130	160	160	190 Max.
Grid Voltage.....	-1.5	-2	-2	-3
Average Plate Current—Millamperes..	0.6	1.0	1.0	1.0
Average Amplification Factor.....	30	30	30	30
Average Plate Resistance—Ohms.....	55,000	50,000	50,000	50,000
*Average Peak Voltage Output.....	30	45	50	65
Second Harmonic—% of Fundamental	2.5	2.5	2	4
Third Harmonic—% of Fundamental..	0.2	0.2	0.2	0.4
Load Resistance—Ohms.....	165,000	150,000	250,000	150,000

\*Input in peak volts is equal to grid voltage.

### Approximate Direct Interelectrode Capacities (measured without sockets)

Plate to Grid.....	9.2 MMF
Plate to Filament.....	1.5 MMF
Grid to Filament.....	3.8 MMF

### Average Static Characteristics

The accompany curves gives the average static characteristics for the 102F tube. These curves have been obtained with the filament operating on direct current and the grid and plate returns connected to the negative end of the filament.

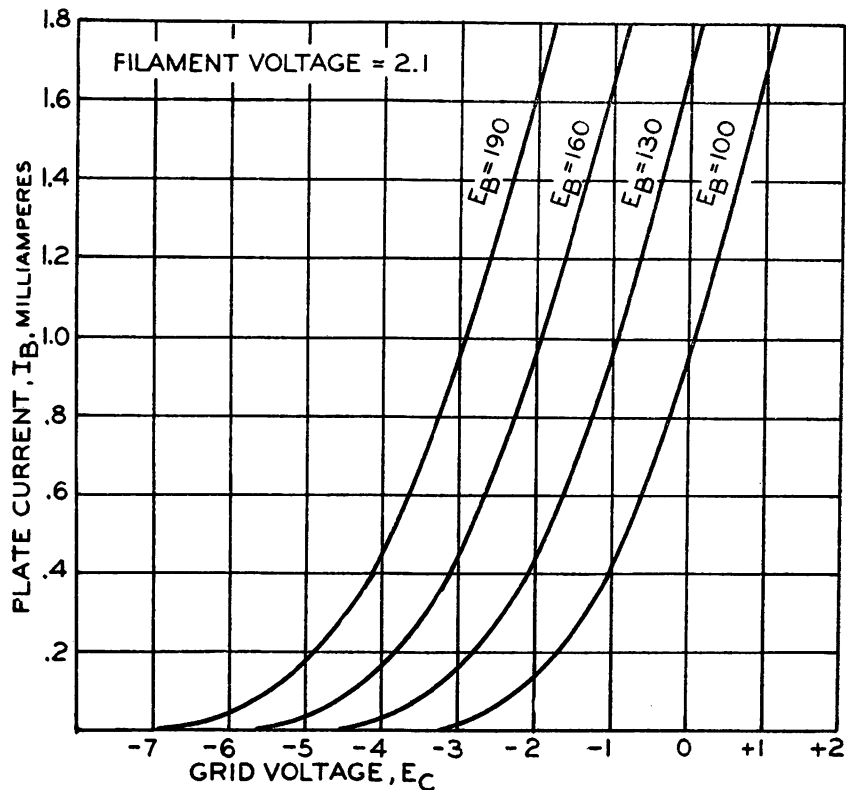

### General Features

An average life of approximately 70,000 hours is obtained when the tube is used in the equipment for which it was designed. This long life feature makes it well suited for continuous operation where very long uninterrupted service is desired.

The prongs of the base are equipped with special contact metal tips to prevent noise disturbance due to poor electrical contact with the springs of the socket.

The characteristics of the 102F tube are similar to those of the 102D. However, the 102F operates at a filament current of 0.5 ampere instead of 1.0 ampere.

## *Western Electric*

### 102F Vacuum Tube

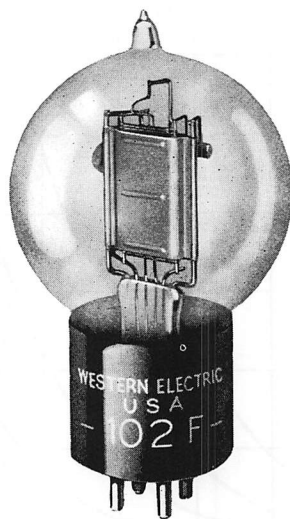

**Classification—Filamentary, voltage amplifier triode**

The 102F tube is designed for the same class of service as the 102D tube but operates with a lower filament power consumption.

**Applications**

Audio-frequency voltage amplifier.  
Detector or modulator.

**Dimensions—**Dimensions, outline diagrams of the tube and base, and the arrangement of the electrode connections to the base terminals are shown in Figures 1 and 2.

**Base—**Medium, four-pin, bayonet type having special contact metal at the ends of the contact pins.

**Socket—**Four-contact, bayonet-slot type, preferably provided with contact-metal contacts, such as the Western Electric 100L for front of panel mounting or 100R for rear of panel mounting.

**Mounting Positions—**Either vertical or horizontal. If mounted in a horizontal position, the plane of the filament, which is indicated in Figure 2, should be vertical.

### Average Direct Interelectrode Capacitances

	<u>A</u>	<u>B</u>	<u>C</u>
Grid to plate, $\mu\mu\text{f.}$ .....	9.2	9.0	9.0
Grid to filament, $\mu\mu\text{f.}$ .....	3.8	4.3	4.6
Plate to filament, $\mu\mu\text{f.}$ .....	1.5	2.9	3.2

Column A—Based tube without socket.

Column B—Tube alone when measured in 100L socket mounted on metal plate; socket and mounting plate connected to filament.

Column C—Tube alone when measured in 100R socket mounted in metal plate; socket and mounting plate connected to filament.

### Filament Rating

Filament current.....	0.50 ampere, d.c.
Nominal filament voltage.....	2.1 volts

The filament of this tube is designed to operate on a current basis and should be operated at as near the rated current as is practicable.

**Characteristics**—Plate current characteristics of a typical 102F tube are shown in Figure 3 as functions of grid voltage for several values of plate voltage. The grid and plate voltages are measured from the negative end of the filament. Corresponding amplification factor, plate resistance, and transconductance characteristics are given in Figures 4, 5 and 6, respectively. Plate current characteristics as functions of plate voltage are shown in Figure 7 for several values of grid voltage.

**Operating Conditions and Output**—Permissible operating plate and grid voltages are included within the area, ABCD, in Figure 3. Amplification factor, plate resistance, transconductance, and performance data are given in the table on page 3 for a number of typical operating conditions represented by selected points within this area. The less severe operating conditions should be selected in preference to maximum operating conditions wherever possible. The life of the tube at maximum conditions may be shorter than at less severe conditions.

The performance data include the fundamental output voltage in peak volts and the second and third harmonic levels in decibels below the fundamental for values of load resistance  $R$ , equal to one, three, and five times the plate resistance,  $r_p$ . The peak value of the sinusoidal input voltage,  $E_{gm}$ , which gives the indicated output voltage,  $E_{pm}$ , and harmonic levels  $F_{2m}$  and  $F_{3m}$ , in each case, is numerically equal to the grid bias. For a smaller input voltage,  $E_g$ , the approximate levels may be computed from the following relations.

$$E_p = E_{pm} \frac{E_g}{E_{gm}}$$

$$F_2 = F_{2m} + 20 \log_{10} \frac{E_{gm}}{E_g}$$

$$F_3 = F_{3m} + 40 \log_{10} \frac{E_{gm}}{E_g}$$

TABLE

<u>Plate Voltage</u>	<u>Grid Bias</u>	<u>Plate Current</u>	<u>Amplification Factor</u>	<u>Plate Resistance</u>	<u>Trans-conductance</u>	<u>Input Voltage</u>	<u>Load Resistance</u>	<u>Output Voltage</u>	<u>Second Harmonic</u>	<u>Third Harmonic</u>
Volts	Volts	Milli-amperes		Ohms $r_p$	Micro-mhos	Peak Volts	R	Peak Volts	db	db
130	-2.0	0.45	29.7	69000	430	2.0	$R = r_p$	26	21	40
							$R = 3r_p$	39	25	44
							$R = 5r_p$	42	26	45
130	-1.5	0.7	30.1	54000	550	1.5	$R = r_p$	21	26	48
							$R = 3r_p$	32	32	55
							$R = 5r_p$	34	33	55
130	-1.0	1.0	30.5	45000	670	1.0	$R = r_p$	15	32	60
							$R = 3r_p$	21	38	65
							$R = 5r_p$	24	40	65
160	-3.0	0.45	29.5	70000	420	3.0	$R = r_p$	40	18	37
							$R = 3r_p$	57	22	40
							$R = 5r_p$	63	23	41
160	-2.0	1.0	30.3	46000	660	2.0	$R = r_p$	29	26	47
							$R = 3r_p$	43	32	55
							$R = 5r_p$	47	33	55
*160	-1.0	1.75	30.8	36000	860	1.0	$R = r_p$	16	37	60
							$R = 3r_p$	22	43	65
							$R = 5r_p$	25	46	65
*190	-3.0	1.0	30.1	46000	650	3.0	$R = r_p$	42	22	40
							$R = 3r_p$	62	28	47
							$R = 5r_p$	66	30	50
*190	-2.0	1.75	30.6	36000	850	2.0	$R = r_p$	30	30	50
							$R = 3r_p$	43	36	60
							$R = 5r_p$	48	39	60

\*Maximum operating conditions.

**Microphonic Noise**—With a plate voltage of 130 volts, a grid bias of -1.5 volts, and a load resistance of 100,000 ohms, the mean microphonic noise output level of the 102F tube, measured in a laboratory reference test set, is 20 decibels below 1 volt. The range of levels of individual tubes extends from 9 to 36 decibels below 1 volt. Since microphonic noise depends on the type and intensity of the mechanical disturbance which produces it, the values given here are useful chiefly for comparison with the levels of other tubes which have been tested in the same way.

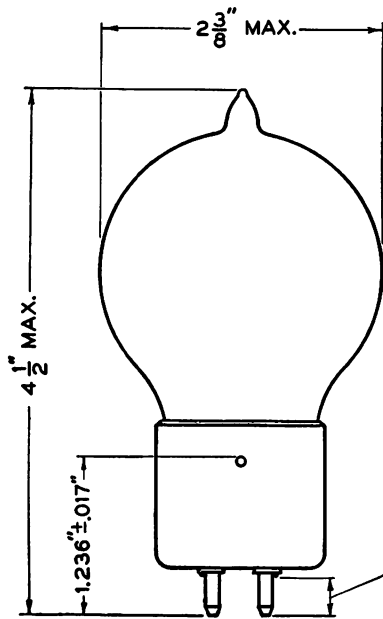

FIG. 1

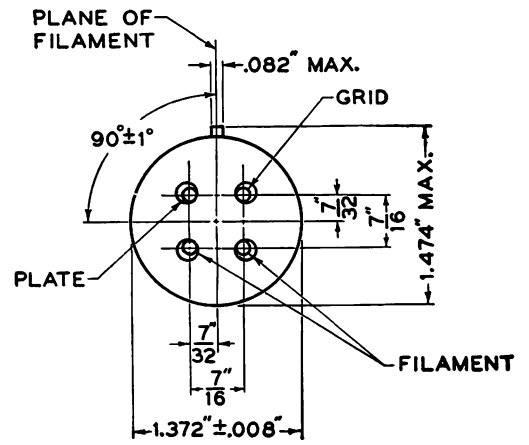

FIG. 2

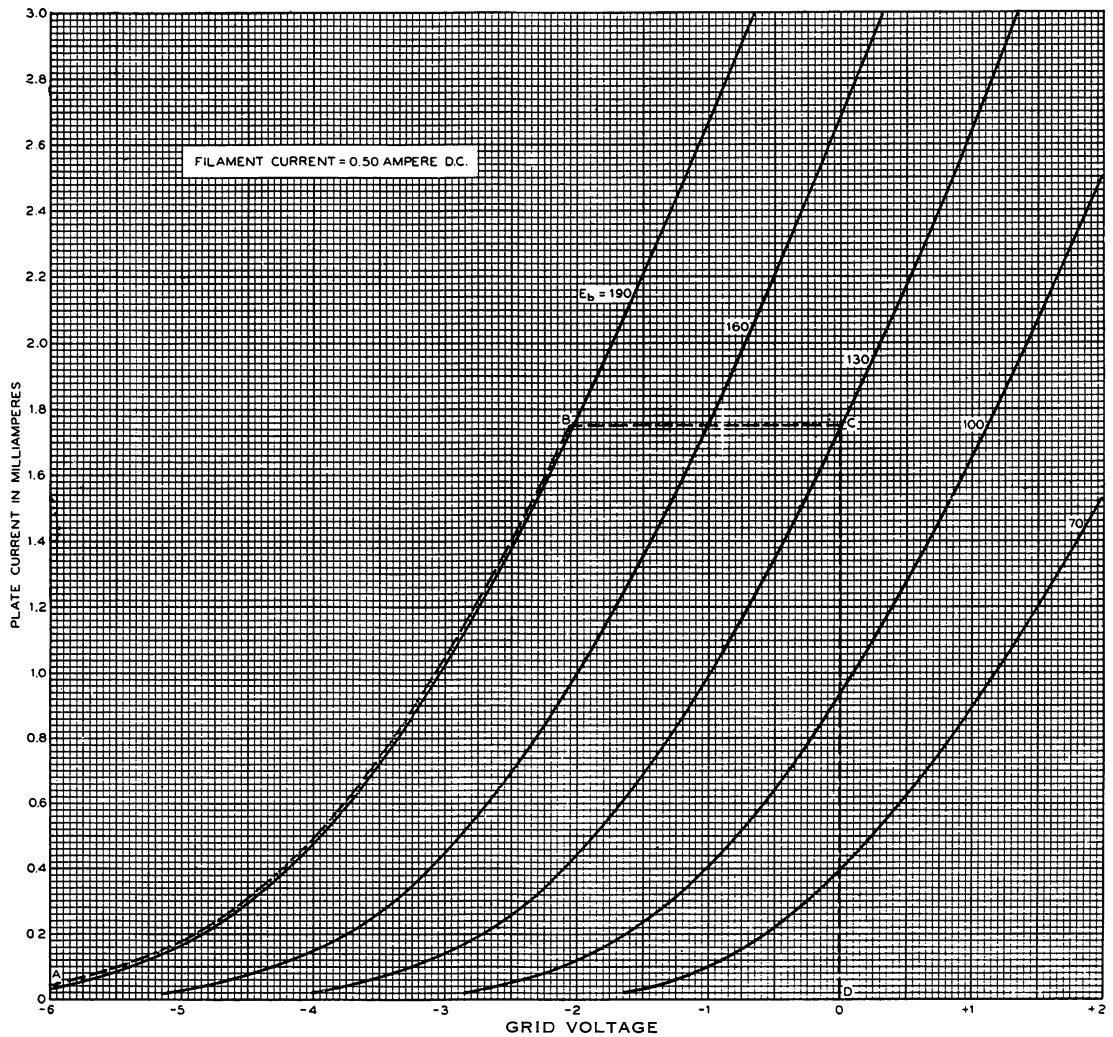

FIG. 3

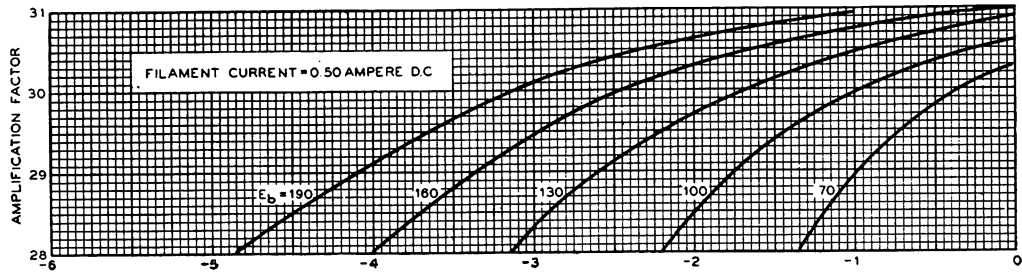

FIG. 4

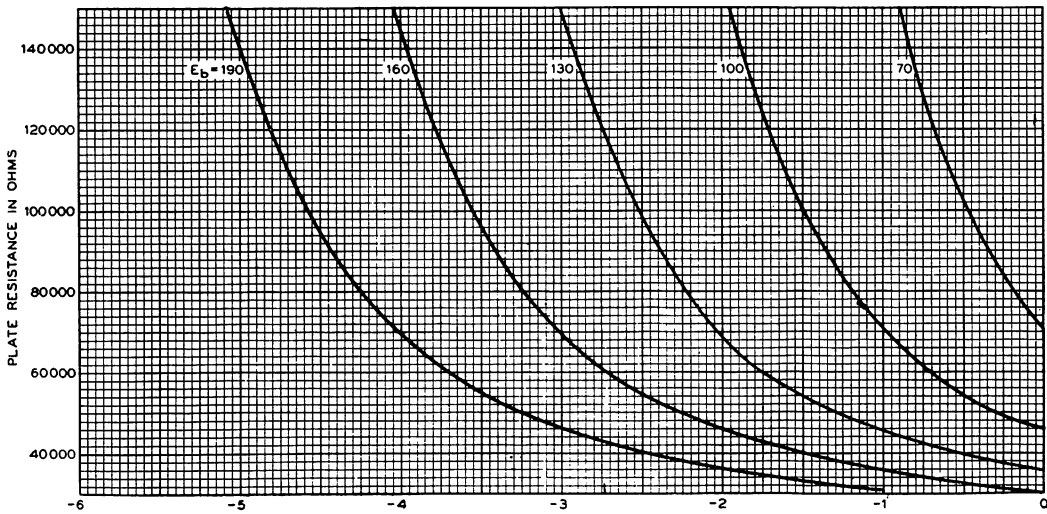

FIG. 5

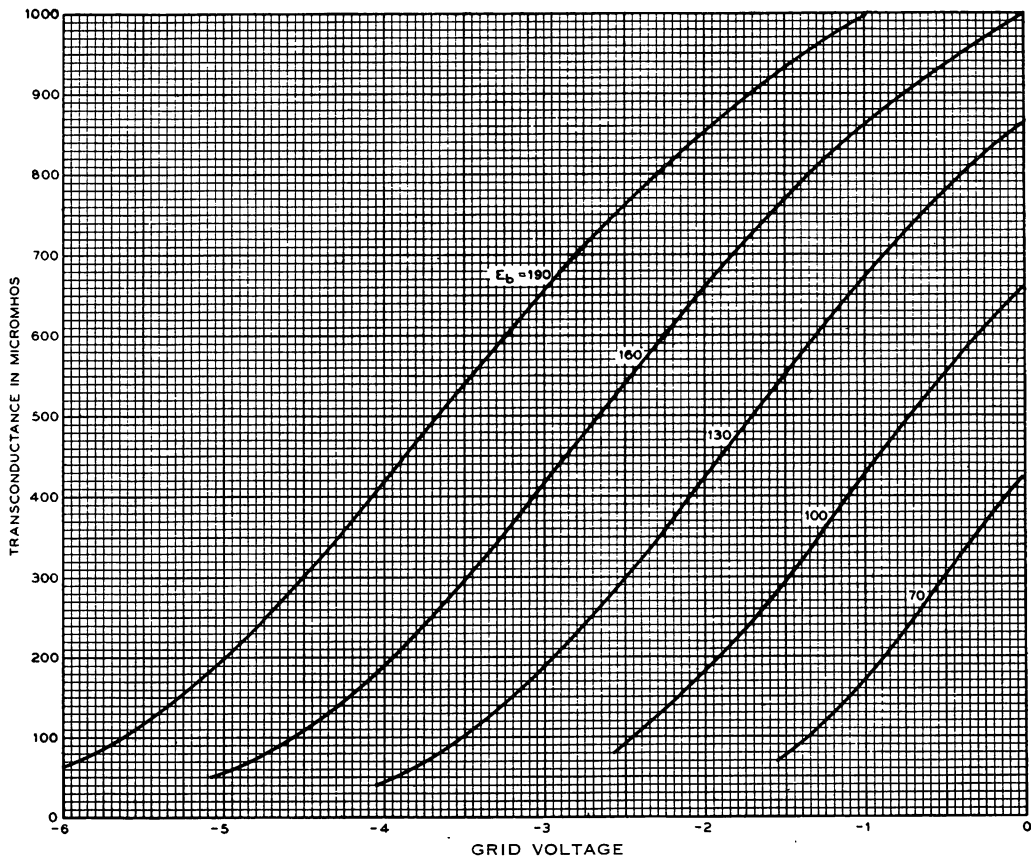

FIG. 6

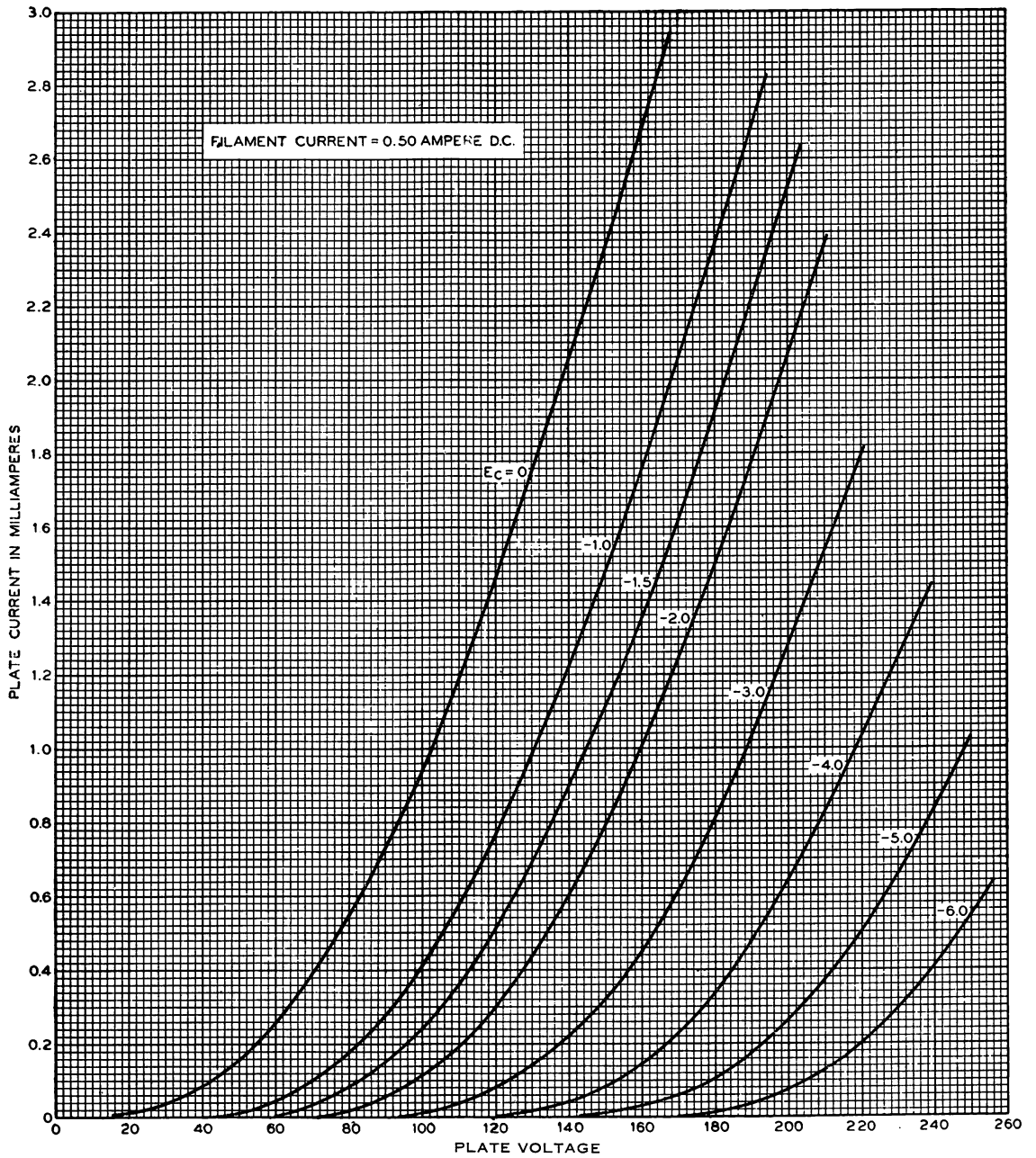
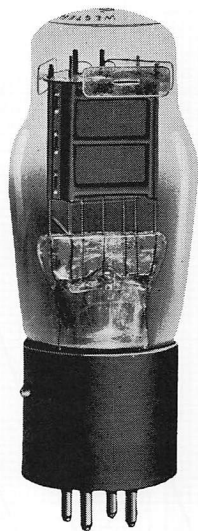

FIG. 7



## *Western Electric*

### **102F Vacuum Tube (Dome)**



#### **Classifications—Filamentary, voltage amplifier triode**

This tube is a redesign of the 102F tube. It includes an improved filament, a new mechanical design using transverse mica supports and is mounted in a dome type bulb. The electrical characteristics are practically identical with the previous 102F tube which it supersedes.

**Applications—**Voltage amplifier for voice-frequency telephone repeaters and carrier-frequency telegraph equipment.

Detector or modulator.

**Dimensions and Connections—**The outline diagrams of the tube and base, giving the dimensions and the arrangement of the electrode connections to the base terminals are shown in Figures 1 and 2.

**Base and Mounting—**This vacuum tube employs a medium, four-pin bayonet type base having special contact metal at the ends of the pins. It is suitable for use in a Western Electric 100L, 100R, or similar type socket, preferably provided with contact-metal contacts.

The tube may be mounted in either a vertical or horizontal position. If mounted in a horizontal position the plane of the filament, which is indicated in Figure 2, should be vertical. To assure adequate ventilation the tubes should be mounted with not less than  $2\frac{5}{8}$  inches between centers when two or more tubes are used.

### Average Direct Interelectrode Capacitances

Grid to plate.....	5.1 $\mu\mu\text{f}$
Grid to filament.....	4.0 $\mu\mu\text{f}$
Plate to filament.....	2.3 $\mu\mu\text{f}$

These values are for a based tube without socket.

### Filament Rating

Filament current.....	0.50 ampere, d.c.
Nominal filament voltage.....	2.1 volts

The filament of this tube is designed to operate on a current basis and should be operated at as near the rated current as practicable.

The filament resistance of this tube increases slightly during the first 2000 hours of operation. The voltage given above is the nominal value after the resistance has stabilized.

**Characteristics**—Typical curves showing plate current as a function of grid voltage for several values of plate voltage are shown in Figure 3. The grid and plate voltages are measured from the negative end of the filament. Corresponding amplification factor, plate resistance and transconductance characteristics are given in Figures 4, 5 and 6 respectively. Plate current as a function of plate voltage for several values of grid voltage is shown in Figure 7.

**Operating Conditions and Output**—Permissible operating plate and grid voltages are included within the area, ABCD in Figure 3. A number of recommended and maximum operating conditions and the corresponding values of amplification factor, plate resistance, transconductance and performance data are given in the table below. Recommended conditions or others of no greater severity should be selected in preference to maximum conditions wherever possible. The life of the tube at maximum operating conditions may be shorter than at less severe conditions.

The performance data shown include the fundamental output voltage in peak volts and the second and third harmonic levels in db below the fundamental for values of load resistance equal to the plate resistance and for load resistances of 100,000 and 300,000 ohms. The peak value of the sinusoidal input voltage  $E_{gm}$ , which gives the indicated output  $E_{pm}$ , and harmonic levels  $F_{2m}$  and  $F_{3m}$ , in each case is numerically equal to the grid bias. For a smaller input voltage  $E_g$ , the approximate levels may be computed from the following relations:

$$E_p = E_{pm} \frac{E_g}{E_{gm}}$$

$$F_2 = F_{2m} + 20 \log_{10} \frac{E_{gm}}{E_g}$$

$$F_3 = F_{3m} + 40 \log_{10} \frac{E_{gm}}{E_g}$$

### Microphonic Noise

For a plate voltage of 130 volts, a grid bias of  $-1.5$  volts and a load resistance of 100,000 ohms, the mean microphonic output level of this tube, measured in a laboratory reference test set is 33 db below 1 volt. The range of levels of individual tubes extends from 25 to 41 db below 1 volt. Since microphonic noise output depends on the type and intensity of the mechanical disturbance which produces it, the values given here are useful chiefly for comparison with the levels of other types of tubes which have been tested in the same way.

**TABLE**

<u>Plate Voltage</u> Volts	<u>Grid Bias</u> Volts	<u>Plate Current</u> Milli-amperes	<u>Amplification Factor</u>	<u>Plate Resistance</u> Ohms	<u>Trans-conductance</u> Micro-mhos	<u>Load Resistance</u> Ohms	<u>Output Voltage</u> Peak Volts	<u>Second Harmonic</u> db	<u>Third Harmonic</u> db
130	-2.0	0.60	30.9	58,000	530	58,000	28	23	39
						100,000	37	28	45
						300,000	49	39	55
130	-1.5	0.85	31.0	50,000	620	50,000	22	30	48
						100,000	30	37	55
						300,000	38	49	65
130	-1.0	1.15	31.0	44,000	700	44,000	14	36	55
						100,000	20	44	60
						300,000	25	56	65
160	-3.0	0.55	30.9	60,000	520	60,000	42	19	33
						100,000	53	23	38
						300,000	71	35	50
160	-2.0	1.15	31.0	45,000	690	45,000	29	30	48
						100,000	39	37	55
						300,000	49	50	65
*160	-1.0	1.85	31.0	39,000	800	39,000	15	41	60
						100,000	21	51	65
						300,000	25	60	65
*190	-3.0	1.15	30.9	45,000	690	45,000	45	26	40
						100,000	62	35	50
						300,000	75	46	60
*190	-2.0	1.85	31.0	39,000	800	39,000	30	35	55
						100,000	41	44	60
						300,000	50	55	65

\*Maximum operating conditions.

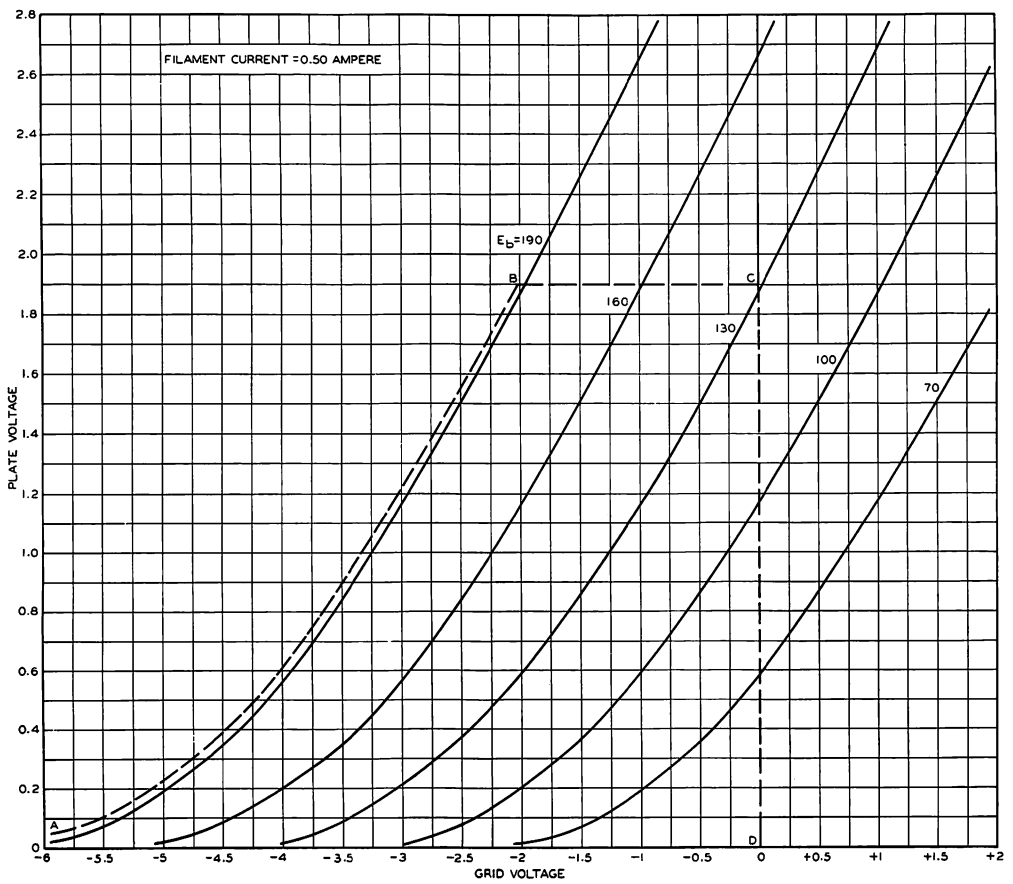
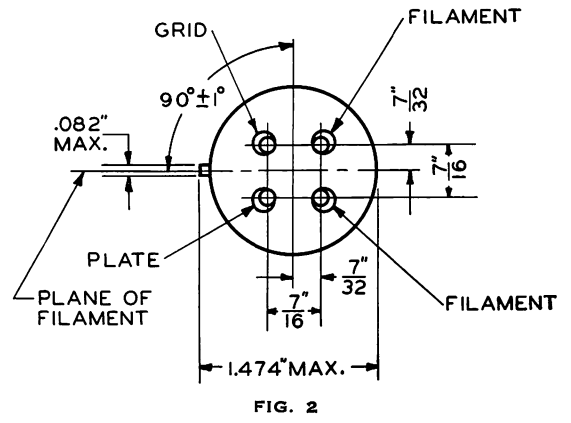
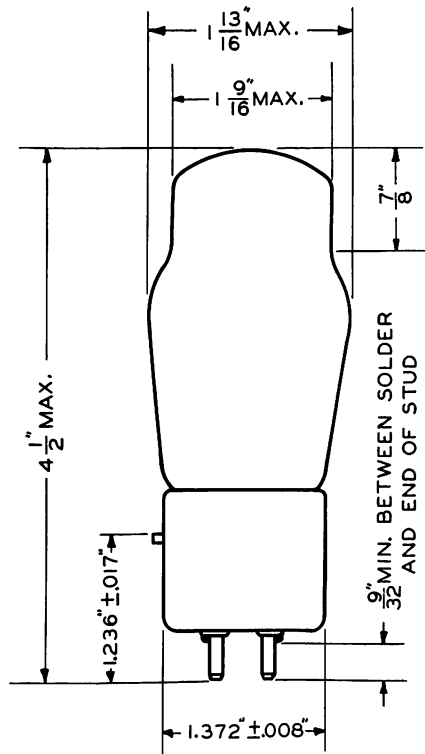

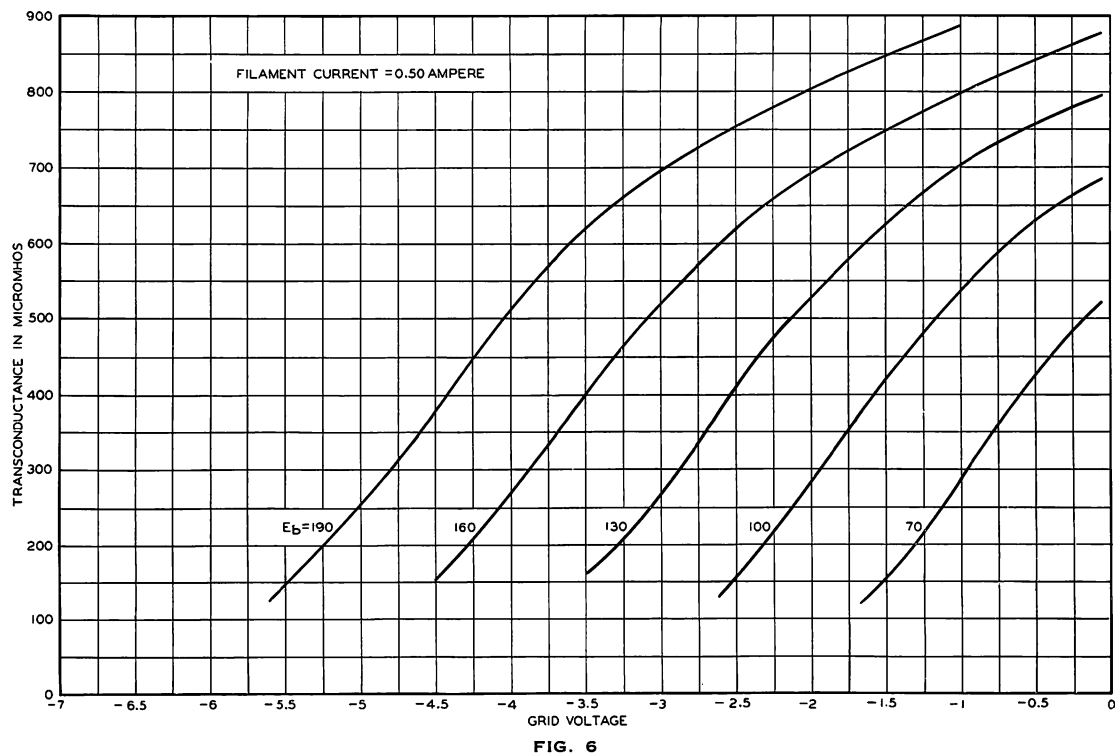
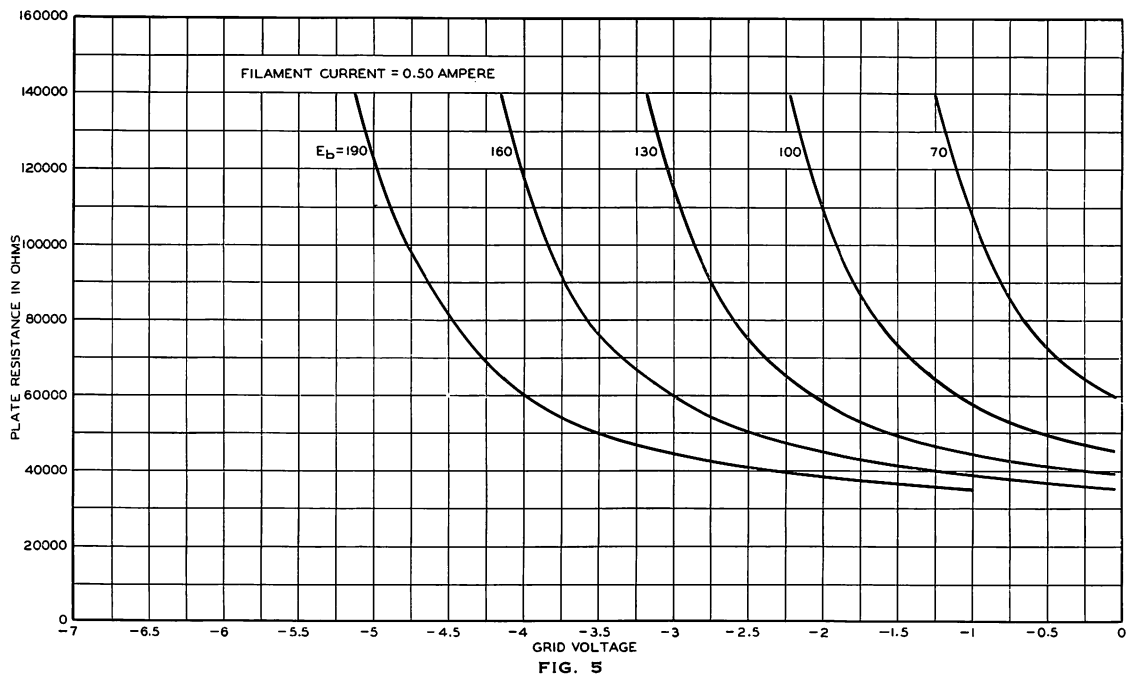
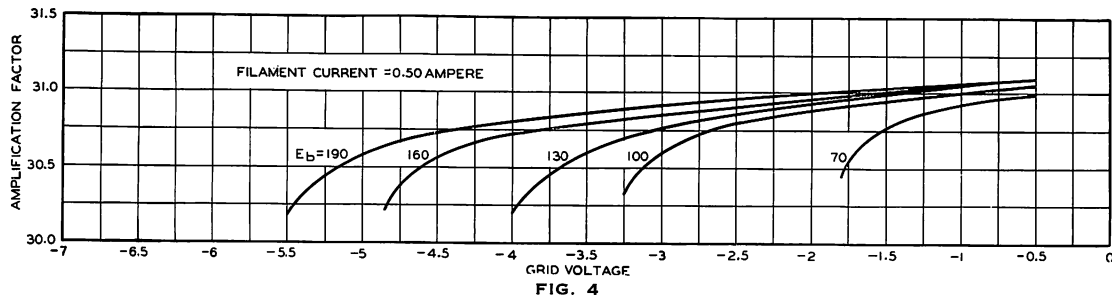

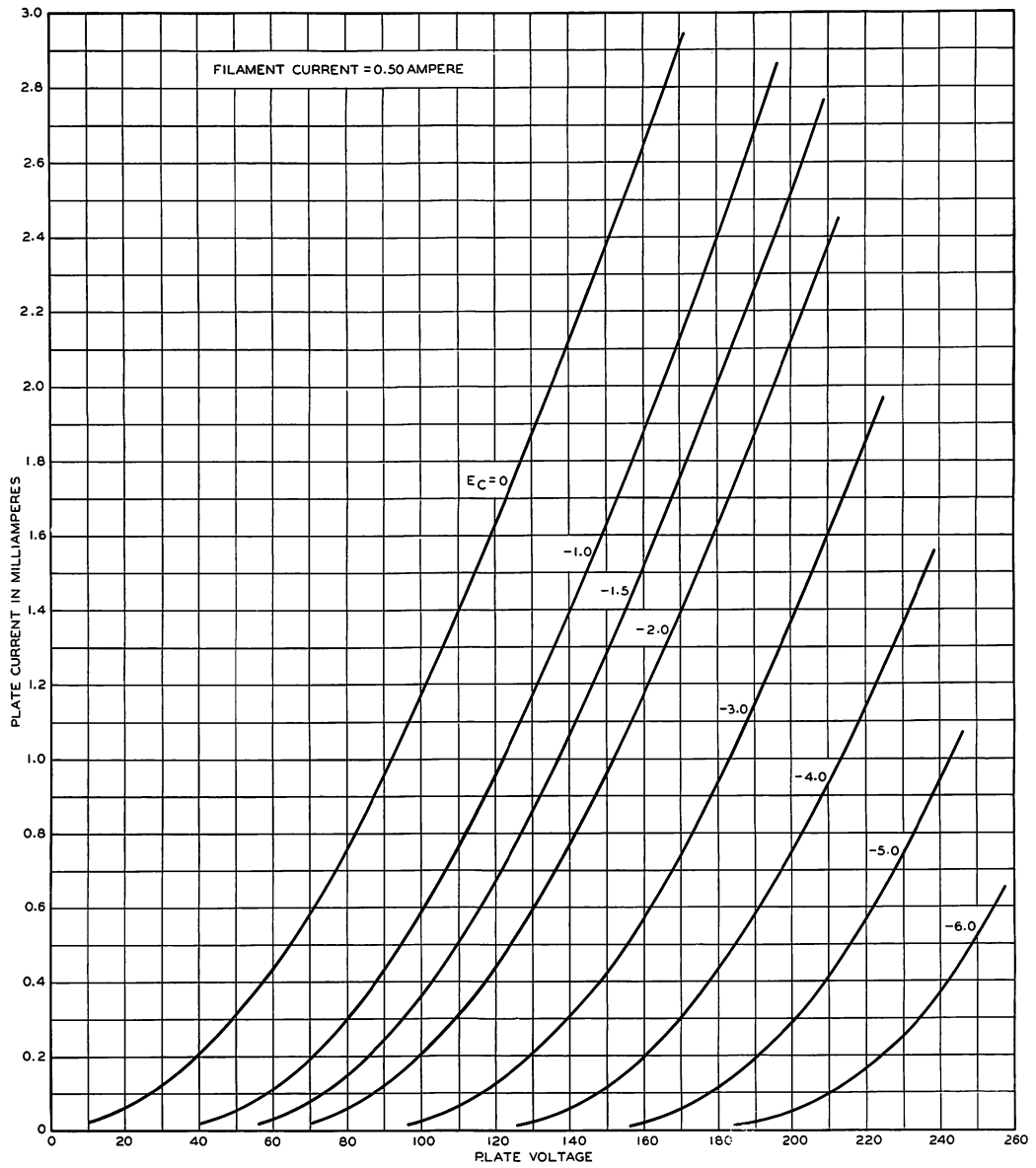

FIG. 7