

256A Vacuum Tube

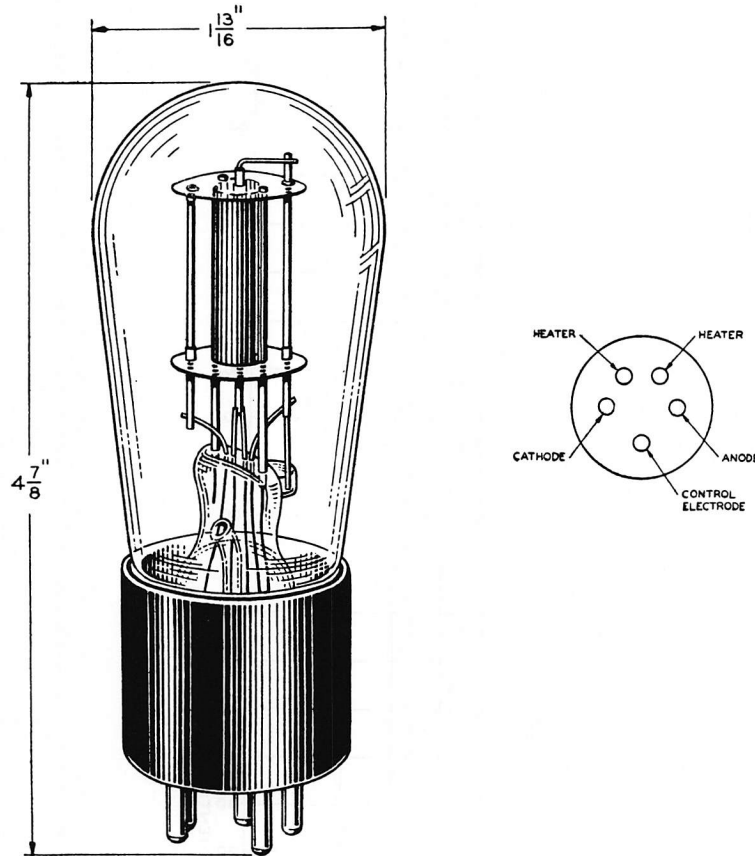

Classification

The No. 256A Vacuum Tube is a three-element tube which employs an indirectly heated cathode and contains argon gas at a low pressure. It is intended for use in special circuits as a relay or trigger-action device.

Base and Socket

The No. 256A Vacuum Tube employs a standard five-prong, thrust-type base suitable for use in a Western Electric 137A or similar type socket. The arrangement of electrode connections to the base terminals is shown above.

Rating and Characteristic Data

Heater Voltage.....	2.3 Volts AC
Nominal Heater Current.....	1.7 Amperes
Anode-Cathode Potential Drop when Conducting.....	10-20 Volts
Maximum Instantaneous Space Current.....	75 Milliamperes
Maximum Instantaneous Potential between Anode and Control-Electrode.....	325 Volts
Maximum Potential between Cathode and Heater.....	12 Volts

Breakdown Characteristics

A typical curve relating the critical control-electrode potential to the anode potential is given in the accompanying chart. This characteristic may vary from tube to tube and during the life of a given tube.

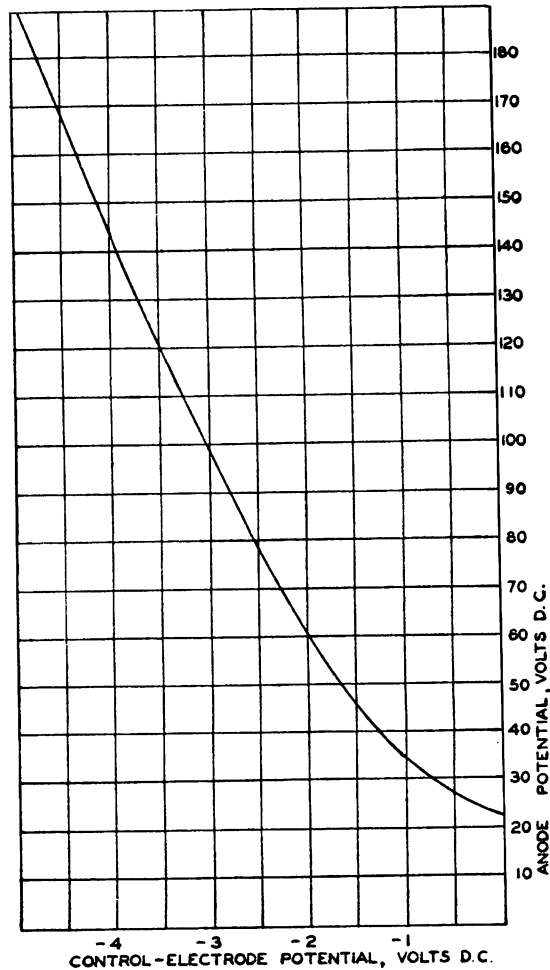

General Features

The No. 256A Vacuum Tube is primarily a rectifier of low internal impedance whose conduction cycle is determined by the relative instantaneous control-electrode and anode potentials. The special treatment of electrode elements and the use of argon gas whose pressure remains practically constant over wide temperature ranges are outstanding design features. The above qualities insure uniform and reproducible characteristics essential to various circuit applications such as; controlled frequency oscillators giving a square wave form, peak voltmeters or volume level indicators, photoelectric cell control and recording equipments, and variable voltage rectifiers.

Western Electric

256A Vacuum Tube

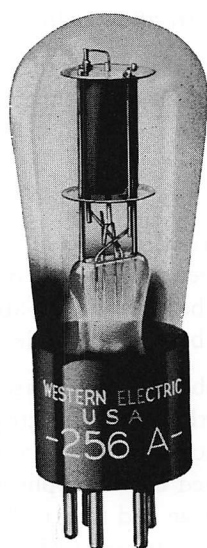

Classification—Three element, argon filled, grid-controlled rectifier with an indirectly heated cathode

It is primarily a rectifier of low internal impedance whose conduction cycle is determined by the relative instantaneous control-electrode and anode potentials. It is intended for use in special circuits as a relay or trigger-action device. A few of its other possible uses are: as a controlled-frequency oscillator giving a square wave-form, as a voltmeter or volume level-indicator, as a source of sweep-voltage for a linear time axis, or as a variable-voltage rectifier.

Dimensions—The dimensions and outline diagrams are given in Figures 1 and 2. The overall dimensions are:

Maximum length.....	$4\frac{7}{8}$ "
Diameter.....	$1\frac{3}{16}$ "

Mounting—The 256A vacuum tube employs a standard five-pin trust type base suitable for use in a Western Electric 141A or similar socket. The arrangement of electrode connections to the base terminals is shown in Figure 2.

It may be mounted in either a vertical or horizontal position, although the vertical position is preferable.

Heater Rating

Heater potential	2.3 volts
Nominal heater current	1.7 amperes

The heater element of this tube is designed to operate on a voltage basis from an alternating current supply. The voltage should be maintained to within 5% of its rated value (2.3 volts). Operation of the heater element above the upper limit will definitely reduce the life of the tube, while a decrease below the lower limit may cause immediate failure.

Sufficient time should always be allowed for the cathode temperature to reach its normal operating value before space current is drawn. If filament transformers with good regulation are used, this time is one minute. Failure to allow sufficient time may result in immediate failure.

The maximum instantaneous potential between the cathode and any point of the heater circuit must not exceed 12 volts. The cathode may be connected to the heater.

Operating Conditions

Anode-cathode potential drop	10—20 volts
Maximum instantaneous space current (sine wave)	75 milliamperes
Maximum instantaneous space current (condenser discharge)	200 milliamperes
Maximum instantaneous potential between anode and control-electrode	325 volts
Maximum instantaneous potential between cathode and heater	12 volts

The characteristics of the 256A tube are such that, for any given anode potential, there is a critical control-electrode potential. If the control-electrode is held more negative than this value and the tube is non-conducting, the space current will remain zero. If it is made less negative, the space current assumes a value determined by the applied anode potential and the resistance in the anode circuit. To extinguish the discharge and return the space current to zero, the positive anode potential must be removed. When space current is flowing, a visible discharge occurs in the tube. Under this condition, the anode-cathode potential is practically independent of the value of both the space current and the control-electrode potential. A protective resistance should always be included in the anode circuit to limit the maximum instantaneous space current to the rated values. A typical curve relating the critical control-electrode potential to the anode potential is shown in Figure 3. This characteristic may vary from tube to tube and during the life of a given tube.

Sufficient resistance must always be included in the grid circuit to limit the negative grid potential to 10 volts when space current is flowing. Failure to observe this precaution will result in short tube life.

Typical Circuits

The tube may be used in a variety of circuits adapted to the application of gas-filled tubes. Two general types are common. One use of the tube is to produce a saw-toothed, current wave. The circuit for this application is shown in Figure 4. The resistance R should, ordinarily, be at least 100,000 ohms, and the product RC (C in farads) approximately equal to the desired fundamental period.

The second general use for the tube is as a relay device. In this application the anode may be supplied from either alternating or direct current. When supplied from direct current, the circuit, Figure 5, possesses a "lock-in" feature, since the anode potential must be removed momentarily in order to restore the tube to the non-conducting condition. When supplied from alternating current, the circuit possesses no "lock-in" feature, but the average anode current may be controlled by the relative phase of control-electrode and anode potentials. The schematic circuit for this application is shown in Figure 6. Figure 7 is a simplified circuit employing a photoelectric cell in place of the resistance, R, used in the phase shifting device in Figure 6. The photoelectric cell, however, is equivalent to a variable resistance in the sense that the current passed will depend upon the amount of light falling upon it.

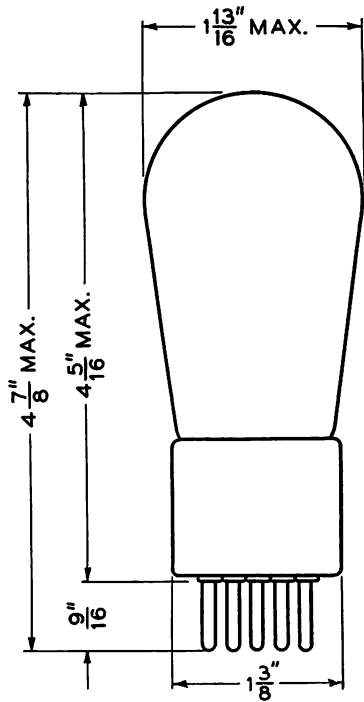

FIG. 1

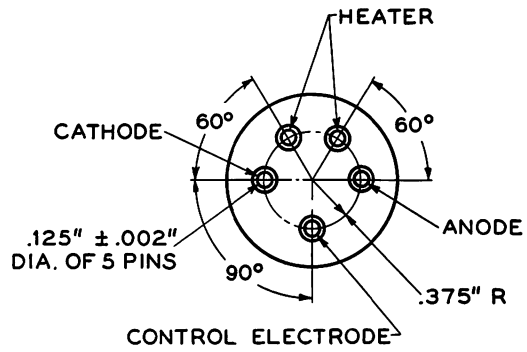

FIG. 2

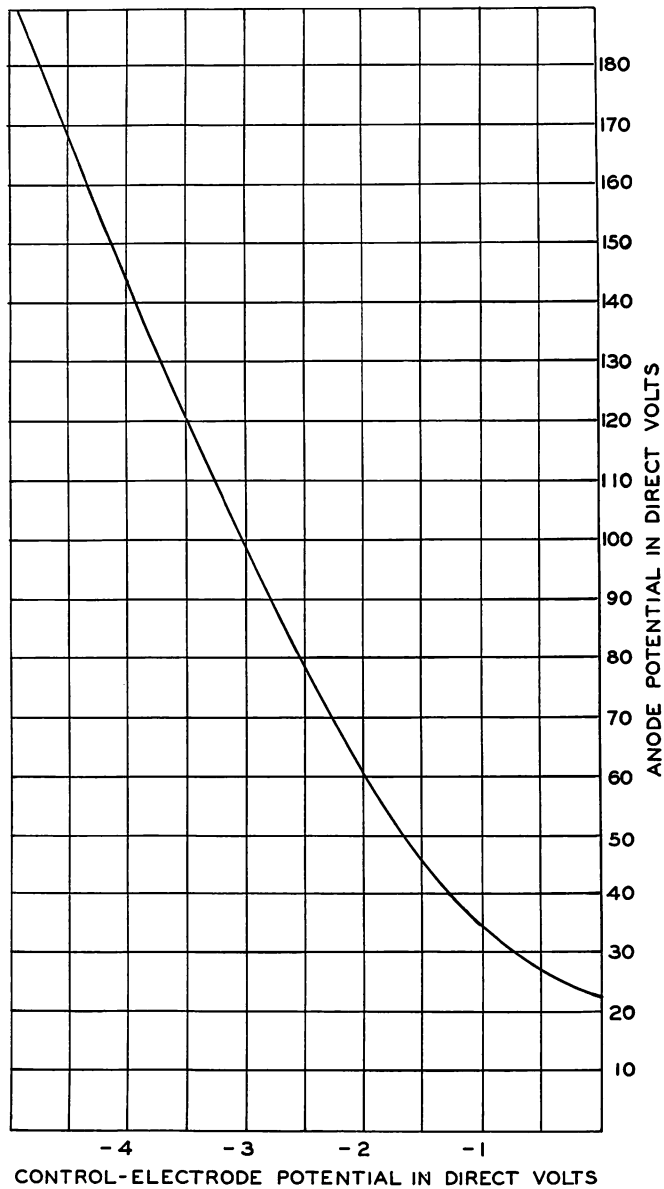

FIG. 3

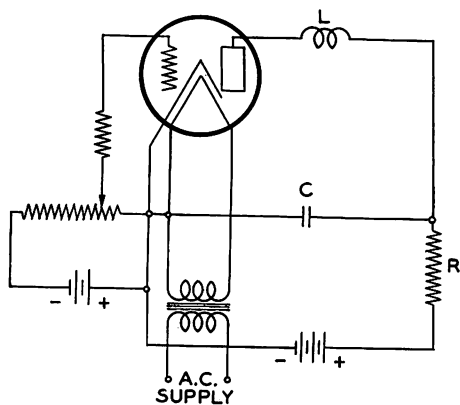

FIG. 4

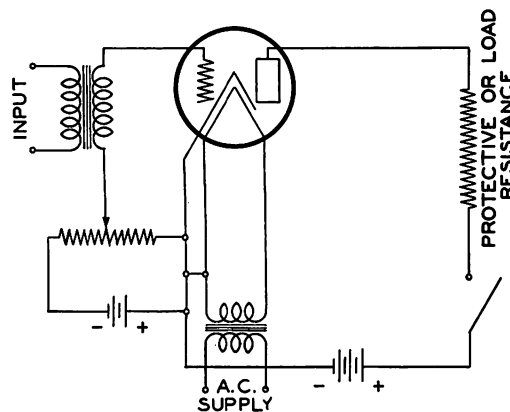

FIG. 5

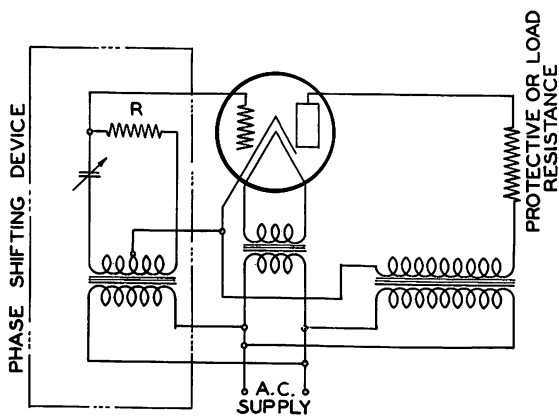

FIG. 6

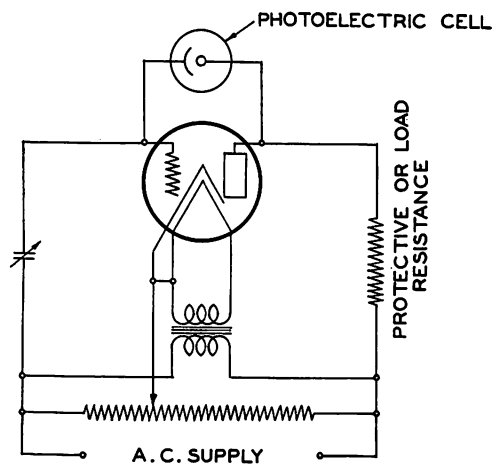

FIG. 7