

## 262A Vacuum Tube

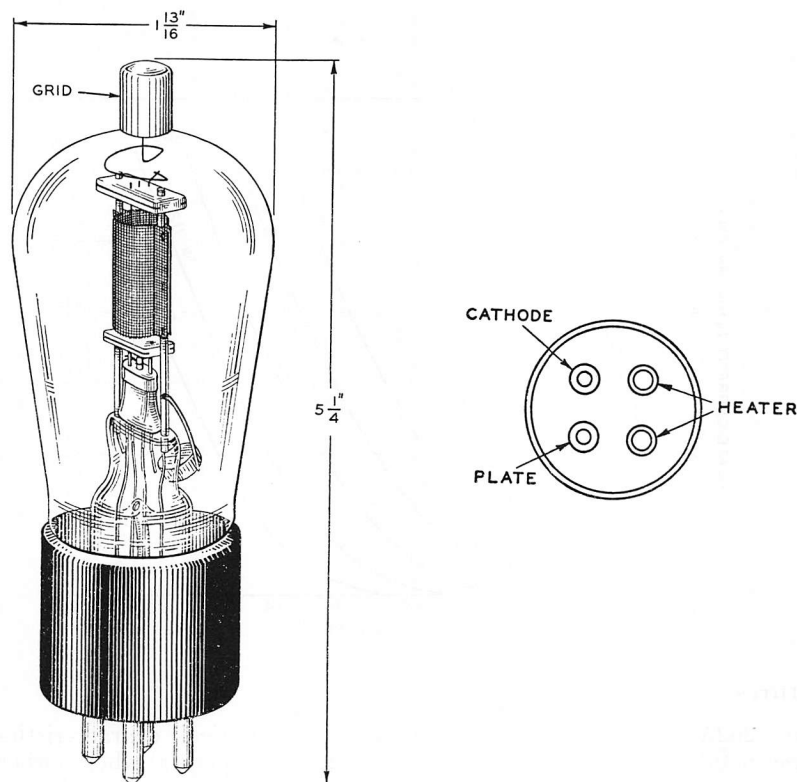

### Classification

The No. 262A Vacuum Tube is a general purpose tube having an indirectly heated cathode designed to permit operation of the heater element directly on alternating current. The tube is for use as an audio-frequency amplifier in high gain circuits.

### Base and Socket

The No. 262A Vacuum Tube employs a standard four-prong base suitable for use in a Western Electric No. 130B (rigid) or No. 131A (cushion) socket or similar type socket. The arrangement of the electrode connections to the base terminals is shown above. The grid terminal is located at the top of the bulb.

### Rating and Characteristic Data

Heater Voltage.....	10 Volts, AC or DC
Average Heater Current.....	0.32 Amperes
Plate Voltage.....	135 180 Volts Maximum
Grid Voltage.....	-6.0 -7.5 Volts
Average Plate Current.....	1.6 2.8 Milliamperes
Average Plate Resistance.....	21,200 17,500 Ohms
Average Amplification Factor.....	14.7 14.9

### Approximate Direct Interelectrode Capacities

Plate to Grid.....	1.9 MMF
Plate to Cathode.....	4.0 MMF
Grid to Cathode.....	1.8 MMF

**Average Static Characteristics**

The accompanying curves give the average static characteristics of the No. 262A Vacuum Tube.

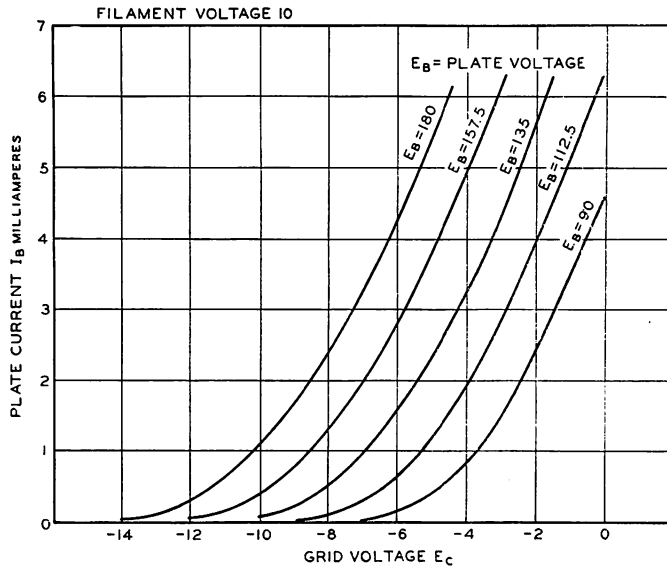

**General Features**

The No. 262A Vacuum Tube is designed with electrical characteristics particularly suitable for use in intermediate stages of audio-frequency amplifiers where either resistance or transformer coupling is used.

By special features in design and by careful control of the manufacturing processes the disturbing hum output due to the use of alternating current in the heater is maintained at an extremely low level. This makes the tube especially suitable, when alternating current filament supply is used, for the early stages of high gain audio-frequency amplifiers where the use of ordinary heater type tubes would be entirely impracticable.

The rigid and non-resonating structure of this tube makes it unusually non-microphonic. Its microphonic response to a given mechanical stimulus is from 10 to 20 db below that of heater tubes of conventional design.

## *Western Electric*

### 262A Vacuum Tube

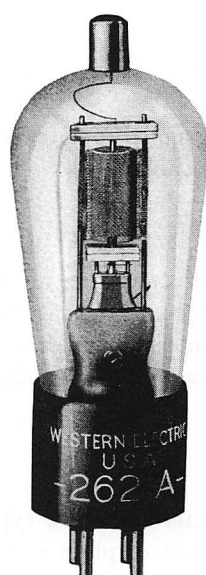

**Classification—Low-power triode with indirectly-heated cathode**

The 262A tube is designed to minimize hum produced by alternating current operation of the heater, and to minimize microphonic noise.

**Application—**Audio-frequency amplifier where alternating current is used for heating the cathode and exceptionally low tube noise is required.

**Dimensions—**Dimensions, outline diagrams of the tube and base, and the arrangement of electrode connections to the base terminals are shown in Figures 1 and 2.

**Base—**Medium, four-pin thrust type having silver-plated pins. Small metal cap grid terminal at the top of the bulb.

**Socket—**Standard, four-contact type, preferably provided with silver-plated contacts such, as the Western Electric 143B socket.

**Mounting Positions**—The 262A tube may be mounted in any position.

**Average Direct Interelectrode Capacitances**

Grid to plate . . . . .	1.9 $\mu\text{mf.}$
Grid to cathode and heater . . . . .	1.8 $\mu\text{mf.}$
Plate to cathode and heater . . . . .	4.0 $\mu\text{mf.}$

**Heater Rating**

Heater voltage . . . . .	10.0 volts, a.c. or d.c.
Nominal heater current . . . . .	0.32 ampere

The heater element of this tube is designed to operate on a voltage basis and should be operated at as near the rated voltage as is practicable.

**Cathode Connection**—Preferably direct to the mid-point of the heater transformer winding or to the mid-point of a low resistance connected across the heater terminals, where alternating heater voltage is used. This connection usually reduces the hum produced in the tube. Where voltage must be applied between the heater and cathode, it should be kept as low as possible and should not exceed 90 volts.

**Characteristics**—Plate current characteristics of a typical 262A tube are shown in Figure 3 as functions of grid voltage for several values of plate voltage. Corresponding amplification factor, plate resistance and transconductance characteristics are given in Figures 4, 5, and 6, respectively. Plate current characteristics are given as functions of plate voltage for several values of grid voltage in Figure 7.

**Operating Conditions and Output**—Permissible operating plate and grid voltages are included within the area, ABCD, in Figure 3. A number of recommended and maximum operating conditions represented by selected points within this area and the corresponding values of amplification factor, plate resistance and transconductance are given in the table on page 4. Recommended conditions or others of no greater severity should be selected in preference to maximum conditions wherever possible. The life of the tube at maximum conditions may be shorter than at the recommended conditions.

In the latter part of the table are given the fundamental power output,  $P_m$ , in milliwatts, the fundamental voltage output,  $E_{pm}$ , in peak volts, and the second and third harmonic levels,  $F_{2m}$  and  $F_{3m}$ , in db below the fundamental, corresponding to each of the recommended and maximum operating conditions for the indicated values of load resistance,  $R$ . The fundamental output is given in terms of power for values of load resistance equal to and double the value of the plate resistance,  $r_p$ , and in terms of voltage for values of load resistance five times the plate resistance.

The peak value of the sinusoidal input voltage,  $E_{gm}$ , in each case is numerically equal to the grid biasing voltage. For a smaller input voltage,  $E_g$ , the fundamental power and voltage output and the harmonic levels are given approximately by the following relations:

$$P = P_m \left( \frac{E_g}{E_{gm}} \right)^2$$

$$E_p = E_{pm} \frac{E_g}{E_{gm}}$$

$$F_2 = F_{2m} + 20 \log_{10} \frac{E_{gm}}{E_g}$$

$$F_3 = F_{3m} + 40 \log_{10} \frac{E_{gm}}{E_g}$$

**Hum**—The disturbance produced in the plate circuit of an indirectly heated cathode type tube by alternating current operation of the heater has two main frequency components. One is of the same frequency as the alternating heater voltage. The other, often larger in magnitude, is of double this frequency. With a plate voltage of 135 volts, a grid bias of  $-4.5$  volts, a load resistance equal to the plate resistance of the tube, and with the cathode connected to the mid-point of the heater circuit, the mean hum output level of the 262A tube at the supply frequency is 110 db below 1 milliamper. The range of levels of individual tubes extends from 95 to 125 db below 1 milliamper. At double the supply frequency, the mean level is 111 db below 1 milliamper, and the range of levels of individual tubes extends from 104 to 118 db below 1 milliamper.

The 262A tube has high insulation resistance and low capacitance between the grid and the heater. When reasonable care is exercised to keep the insulation leakage and capacitance small between the grid and heater leads in the external wiring, a resistance of 2 megohms may be used in the grid circuit without materially affecting the hum level.

**Microphonic Noise**—With a plate voltage of 135 volts, a grid bias of  $-4.5$  volts and a load resistance of 100,000 ohms, the mean microphonic noise output level of the 262A tube measured in a laboratory reference test set is 50 db below 1 volt. The range of levels of individual tubes extends from 38 to 62 db below 1 volt. Since microphonic noise depends on the type and intensity of the mechanical disturbance which produces it, the values given here are useful chiefly for comparison with the levels of other tubes which have been tested in the same way.

**Fluctuation Noise**—An irreducible minimum of noise in a vacuum tube is produced by uncontrollable, minute fluctuations in the rate of flow of electrons to the anode. With a plate voltage of 135 volts, a grid bias of  $-4.5$  volts, and a load resistance of 100,000 ohms, the mean equivalent fluctuation noise input of the 262A tube for the audio-frequency range from 40 to 10,600 cycles is 112.4 db below 1 volt. Individual 262A tubes may differ from this value by as much as 5 db. By reducing the plate voltage to 36 volts and the grid bias to  $-1$  volt, the mean fluctuation noise level may be reduced by about 7.5 db, without seriously affecting the voltage amplification. The equivalent noise input voltage is equal to the measured output voltage divided by the voltage amplification of the tube in the measuring circuit.

TABLE

	<u>Plate Voltage</u> Volts	<u>Grid Bias</u> Volts	<u>Plate Current</u> Milli- amperes	<u>Ampli- fication Factor</u>	<u>Plate Resis- tance</u> Ohms $r_p$	<u>Trans- con- duc- tance</u> Micro- mhos	<u>Load Resis- tance</u> R	<u>Power Out- put</u> Milli- watts	<u>Volt- age Out- put</u> Peak Volts	<u>Sec- ond Har- monic</u> db	<u>Third Har- monic</u> db						
Recom- mended Operat- ing Condi- tions	90	-4.0	0.9	14.3	23800	600	R = $r_p$	17	—	21	42						
							R = $2r_p$	15	—	23	55						
							R = $5r_p$	—	50	30	55						
	90	-3.0	1.6	15.0	18500	810	R = $r_p$	13	—	23	55						
							R = $2r_p$	12	—	27	60						
							R = $5r_p$	—	40	32	55						
	90	-2.0	2.5	15.6	15700	990	R = $r_p$	8	—	28	55						
							R = $2r_p$	7	—	31	60						
							R = $5r_p$	—	30	36	70						
	112.5	-4.5	1.6	14.7	19100	770	R = $r_p$	30	—	20	47						
							R = $2r_p$	25	—	25	65						
							R = $5r_p$	—	67	30	55						
	112.5	-3.0	2.9	15.5	15000	1030	R = $r_p$	17	—	26	60						
							R = $2r_p$	15	—	30	70						
							R = $5r_p$	—	40	33	60						
	*135	-7.5	0.7	13.7	29000	470	R = $5r_p$	—	95	25	50						
							135	-6.0	1.6	14.4	19600	730	R = $r_p$	45	—	19	42
													R = $2r_p$	40	—	23	55
R = $5r_p$	—	75	29	50													
135	-4.5	2.8	15.1	15400	980	R = $r_p$	35	—	23	60							
						R = $2r_p$	30	—	27	60							
						R = $5r_p$	—	60	31	55							
*157.5	-8.0	1.4	14.0	22000	640	R = $5r_p$	—	100	26	50							
						157.5	-7.0	2.0	14.5	18200	800	R = $r_p$	65	—	18	42	
												R = $2r_p$	60	—	23	55	
R = $5r_p$	—	90	29	50													
Maxi- mum Operat- ing Condi- tions	112.5	-2.0	4.0	16.0	13400	1190	R = $r_p$	9	—	31	55						
							R = $2r_p$	8	—	34	60						
							R = $5r_p$	—	30	38	65						
	135	-3.5	3.8	15.6	13700	1140	R = $r_p$	25	—	26	55						
							R = $2r_p$	20	—	30	70						
							R = $5r_p$	—	47	33	70						
	157.5	-5.5	3.3	15.1	14800	1020	R = $r_p$	55	—	22	55						
							R = $2r_p$	50	—	27	60						
							R = $5r_p$	—	70	31	50						
	*180	-10.5	0.9	13.6	28800	470	R = $5r_p$	—	130	23	42						
	*180	-9.0	1.7	14.1	20200	700	R = $5r_p$	—	110	27	50						
	180	-7.5	2.8	14.7	16200	910	R = $r_p$	90	—	20	46						
							R = $2r_p$	80	—	24	60						
							R = $5r_p$	—	95	30	50						

\*Operating conditions applicable primarily for voltage amplification.

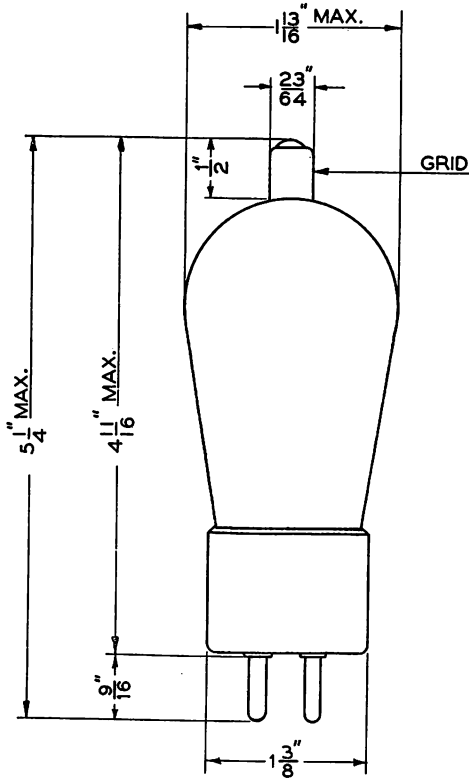

FIG. 1

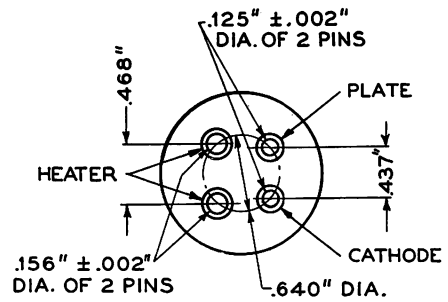

FIG. 2

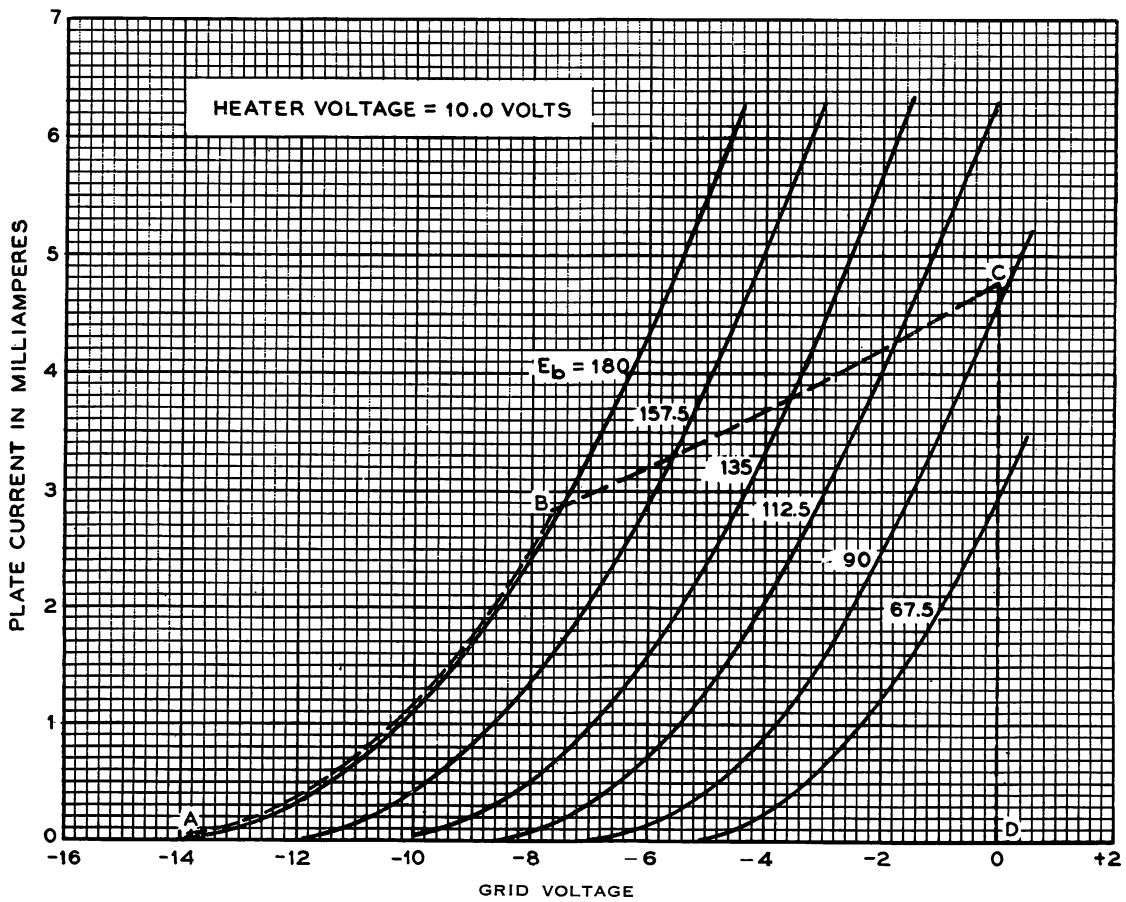

FIG. 3

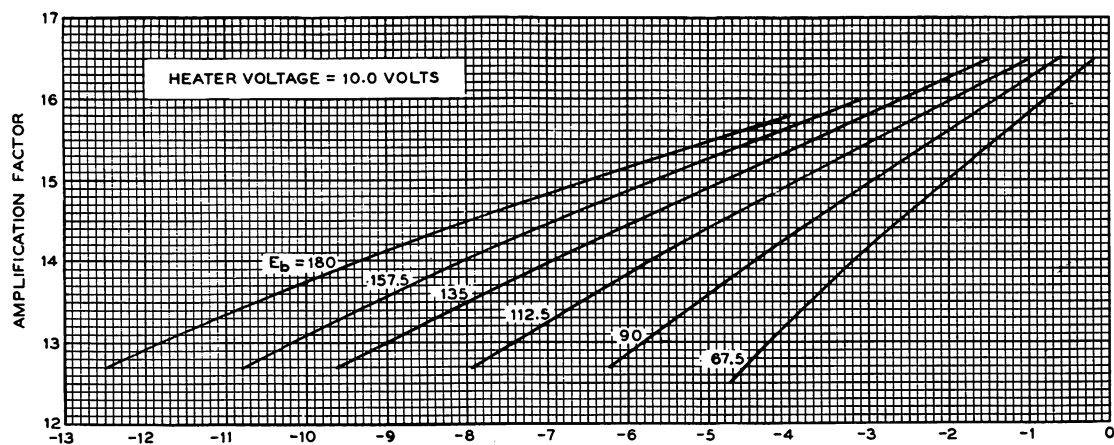

FIG. 4

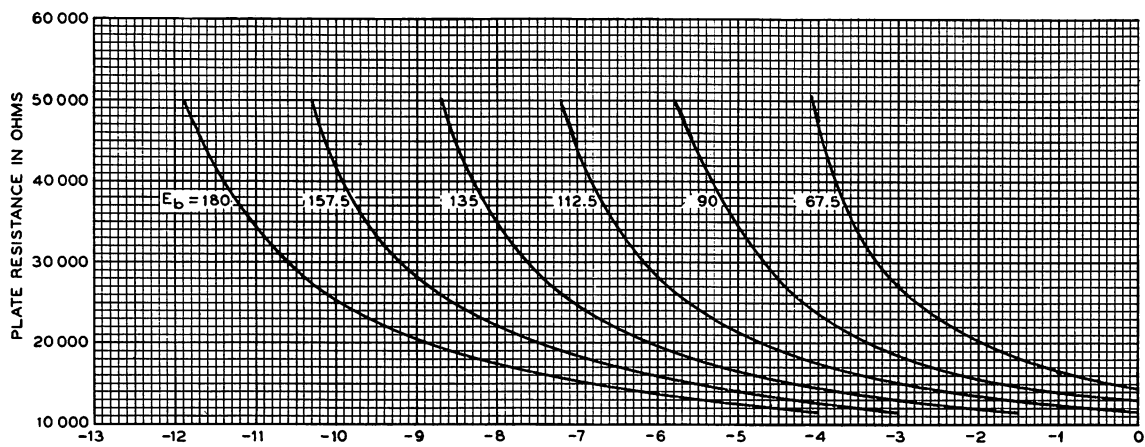

FIG. 5

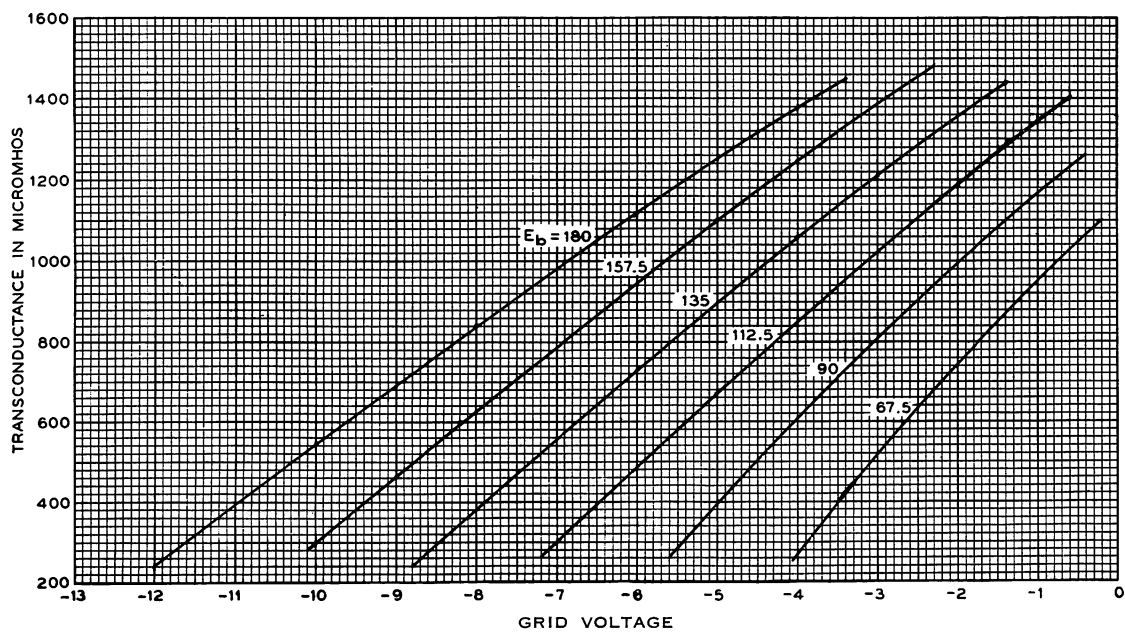

FIG. 6



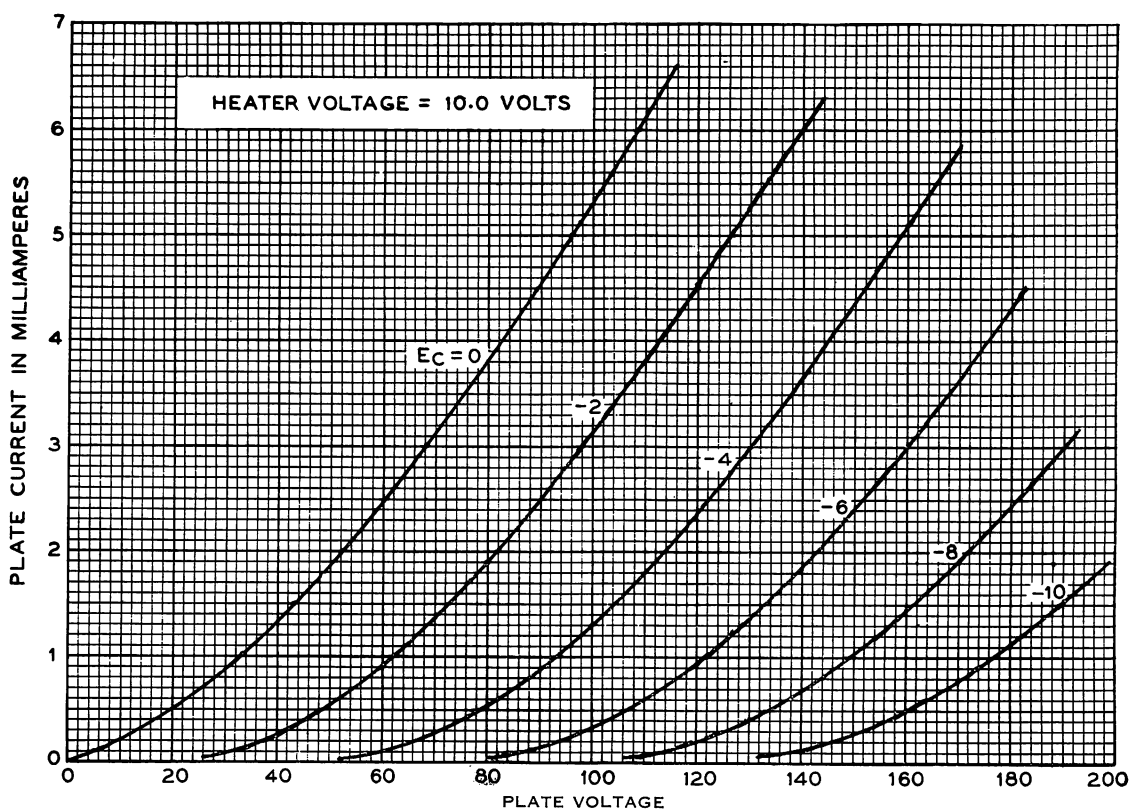

FIG. 7