

## 263A Vacuum Tube

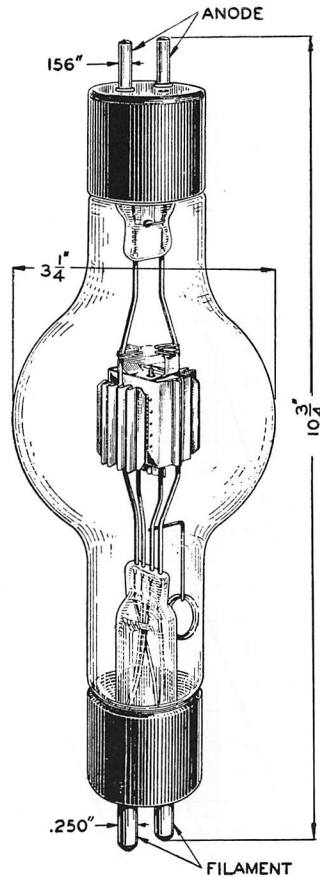

### Classification

The No. 263A Vacuum Tube is a double half wave, thermionic, gas-filled rectifier for use in rectifying circuits designed to supply direct current at a low voltage from an alternating current supply.

### Base and Socket

The No. 263A Vacuum Tube is a double-ended tube employing a two-prong, push-type base suitable for use in a Western Electric 139B socket or similar type socket. The anode terminals at the top are arranged for use with a Western Electric 280A plug or with flexible lead connectors. The tube should be mounted only in a vertical position with the filament terminal end down. The arrangement of electrode connections to the tube terminals is shown above.

### Rating and Characteristic Data

Filament Voltage.....	2.5 Volts
Filament Current.....	15 Amperes
Approximate Anode-Cathode Potential Drop when Conducting.....	8 Volts
Maximum Peak Plate Current.....	6 Amperes
Maximum Continuous Potential between Electrodes.....	100 Volts

For specific rectifying circuits the following ratings apply:

Type of Circuit	No. of Tubes	Load Potential Volts	Load Current Amperes
Single Phase—Double Half-Wave.....	1	25	4
Single Phase—Double Half-Wave in Parallel.....	2	25	8
Single Phase—Double Half-Wave..... (Two Tube Series Circuit)	2	50	4
Three Phase—"Y" Circuit.....	3	40	10
Three Phase—Double "Y" Inter-connected.....	3	30	10

### Average Static Characteristics

The accompanying curve gives the anode-cathode potential drop with respect to the plate current for a typical 263A Vacuum Tube. The exact value varies from tube to tube and during the life of a given tube. Within the specified plate current range, it will vary from 4 to 12 volts.

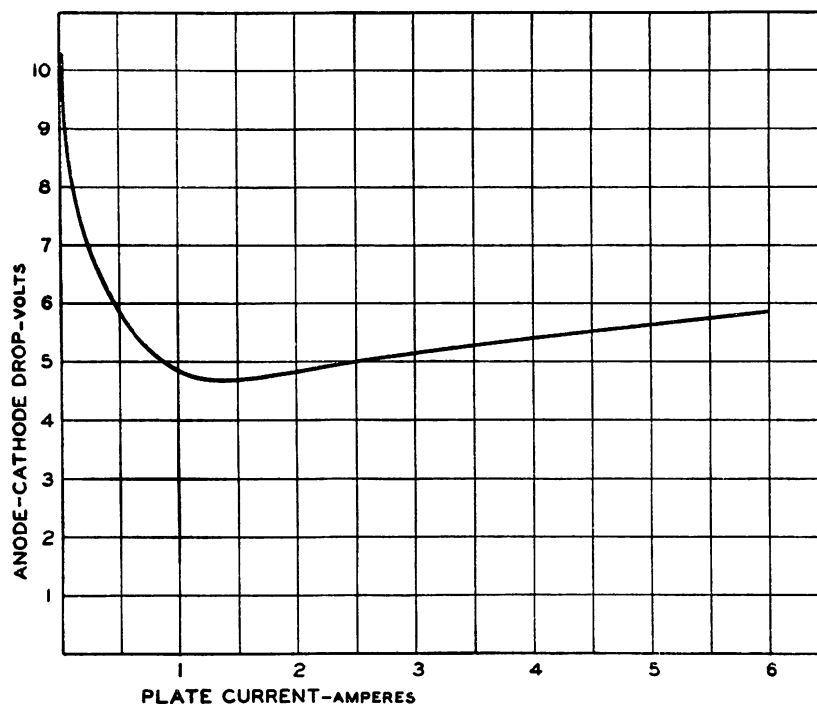

### General Features

The No. 263A Vacuum Tube employs two anodes in the same bulb, thereby making one tube serve the purpose of two tubes when used in full wave rectifying circuits. The bulb is filled with argon gas which makes the current and voltage outputs independent of ambient temperatures. This gas-filling makes the 263A tube suitable for rectifier equipment subject to wide range of ambient temperatures and where a very constant voltage supply is necessary. For other power supply applications, the 263B mercury vapor tube should be used.

The tube uses a very efficient and rugged type of oxide coated cathode employed in other gas-filled rectifiers. The elements are tied together in such a manner as to form a very rugged mechanical structure. This lends itself to a simple and adequate circuit mounting.

## *Western Electric*

### 263A Vacuum Tube

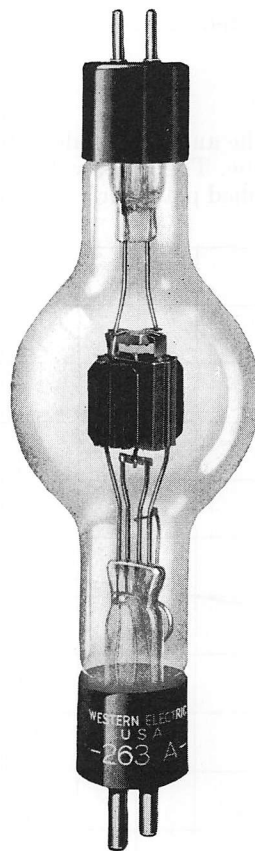

**Classification—Full-wave, thermionic, argon-filled rectifier**

The 263A vacuum tube is designed to supply direct current from an alternating-current supply.

**Dimensions—**The dimensions and outline diagrams are given in Figure 1. The overall dimensions are:

Maximum length.....	10 $\frac{3}{4}$ "
Maximum diameter.....	3 $\frac{1}{4}$ "

**Mounting—**The 263A is a double-ended vacuum tube employing a two-pin, thrust type base suitable for use in a Western Electric 139A or similar socket. The anode terminals at the top of the bulb are arranged for use with a Western Electric 280A plug or with flexible lead connectors. Since the anode and filament terminals cannot be held in exactly the same plane, rigid mounting connectors should not be used for both sets of terminals.

**Base**—Dimensions and the arrangement of electrode connections to the base terminals are shown in Figure 1.

**Mounting Positions**—The tube should be mounted preferably in a vertical position with the filament terminal end down. If the tube is mounted horizontally, the plane of the anode and filament terminals should also be horizontal. There should be a free circulation of air around the tube. No object should touch the glass bulb.

### Filament Rating

Filament voltage.....	2.5 volts
Nominal filament current.....	15 amperes

The filament of this tube is designed to operate on a voltage basis from an alternating-current supply. The voltage should be maintained to within 5% of its rated value (2.5 volts). Operation of the filament at a voltage above the upper limit will definitely reduce the life of the tube while a decrease in voltage below the lower limit may cause immediate failure.

Sufficient time must always be allowed for the filament temperature to reach its normal operating value before the anode potential is applied. If filament transformers with good regulation are used, this time is 2 minutes.

### Characteristics and Operating Conditions

Approximate anode-cathode potential drop.....	8 volts
Maximum peak plate current.....	6 amperes
Maximum peak potential between electrodes.....	100 volts

The anode-cathode potential drop is substantially independent of the plate current. The exact value varies from tube to tube and during the life of a given tube, ranging from 4 to 12 volts.

The anode-cathode potential drop as a function of plate current is shown in Figure 2, for a typical 263A vacuum tube.

The maximum permissible peak plate current (6 amperes) is a limitation on the instantaneous value that the tube can carry safely in the direction in which it is designed to conduct and should not be exceeded. The maximum direct load current is not fixed but will depend upon the wave form required by the load and filter circuit.

The maximum permissible peak potential between electrodes (100 volts) is a limitation on the instantaneous value that the tube can stand safely. If it is exceeded, an arc-back may result which will injure the tube. The maximum rectified potential available is not fixed but will depend upon the type of circuit used.

263A vacuum tubes may be operated in parallel if some provision is made to insure a proper division of the load current. Current dividing reactors or ballasting resistors in series with each anode, may be used for this purpose. The size of the reactors or resistors depends upon the circuit design.

In most cases the termination of the useful life of the 263A tube is due to the loss of filament activity. This causes the tube to fail by arcing between the anodes. Failures of this kind should be safeguarded by proper fuse protection to prevent injury to other tubes in the circuit and to the auxiliary equipment.

**Typical Rectifier Circuits**—The 263A vacuum tube may be used in any standard high vacuum rectifier circuit subject to its current and voltage limitations. Typical circuits are shown below. The approximate direct output current and voltage for each type of rectifier circuit where tubes are operated at maximum permissible plate current and inverse voltage are given in Table 1. The values listed below are average values of the pulsating current and voltage for an unfiltered circuit.

**Table 1**

Circuit Designation	Phase Supply	Number of Tubes	Load Potential in Volts	Load Current in Amperes
A	1	1	25	4
B	1	2	25	8
C	1	2	50	4
D	3	3	40	10
E	3	3	30	10

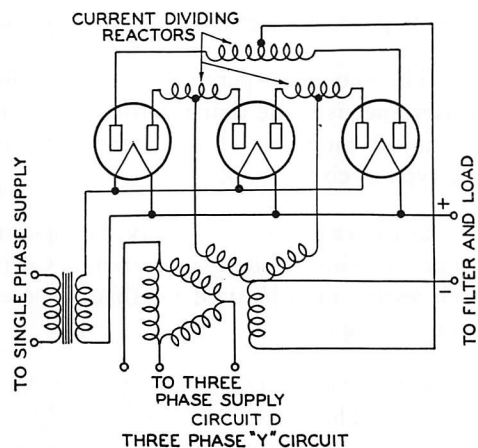
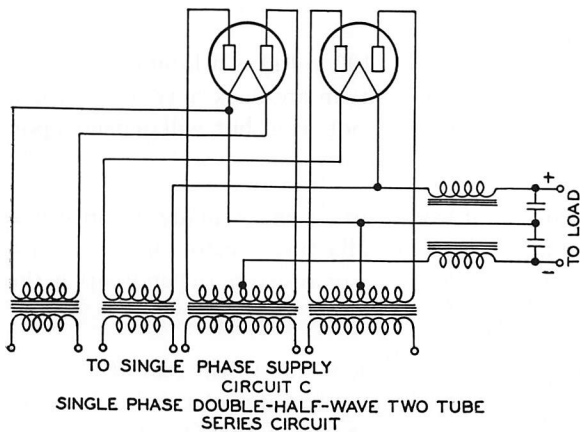
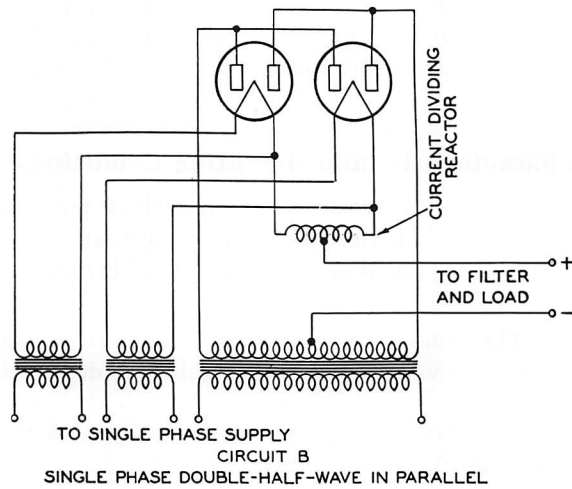
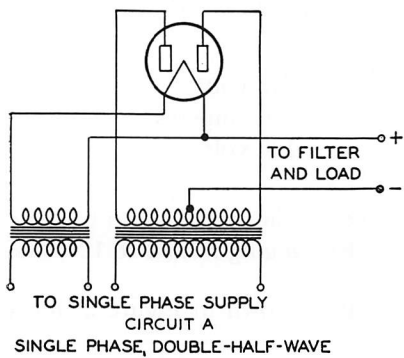

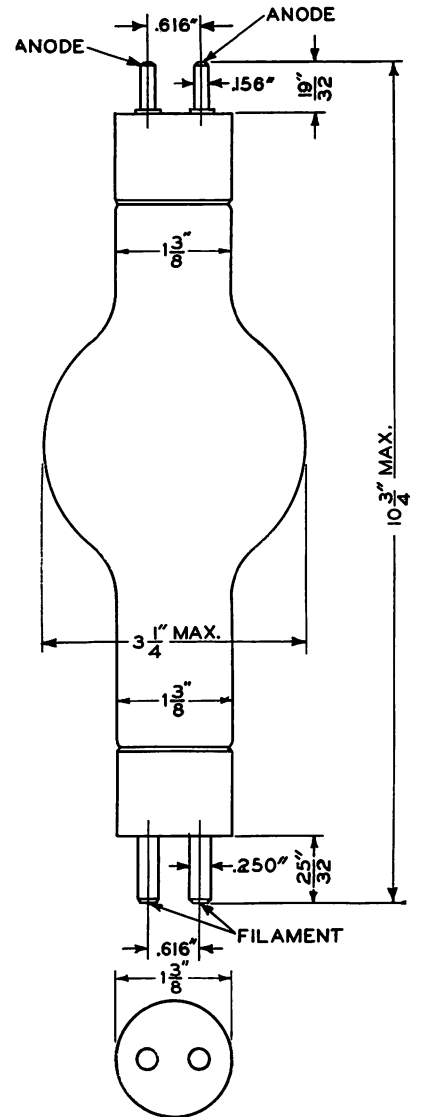
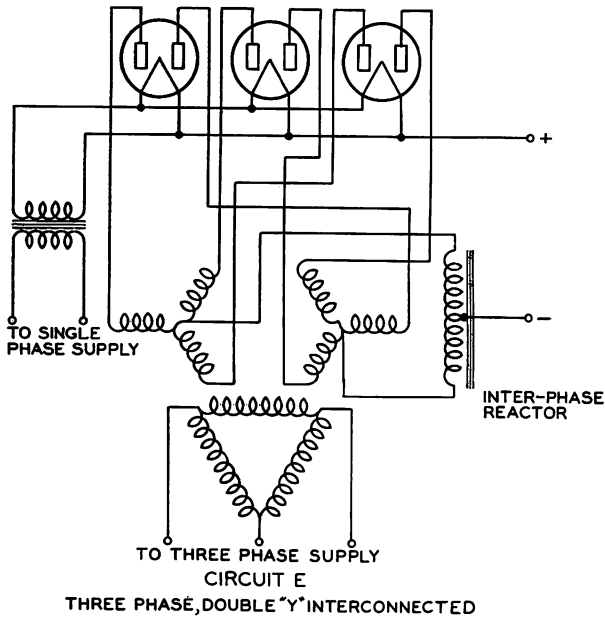

FIG. 1

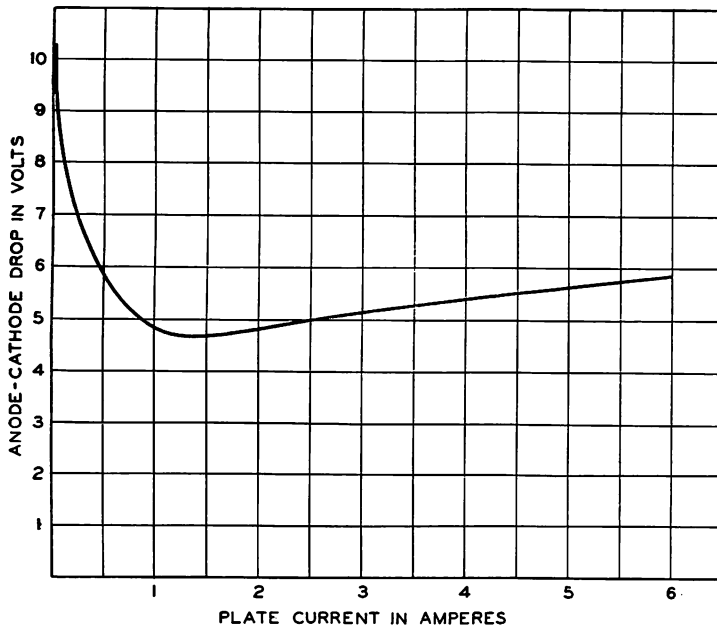

FIG. 2