

## 286A Vacuum Tube

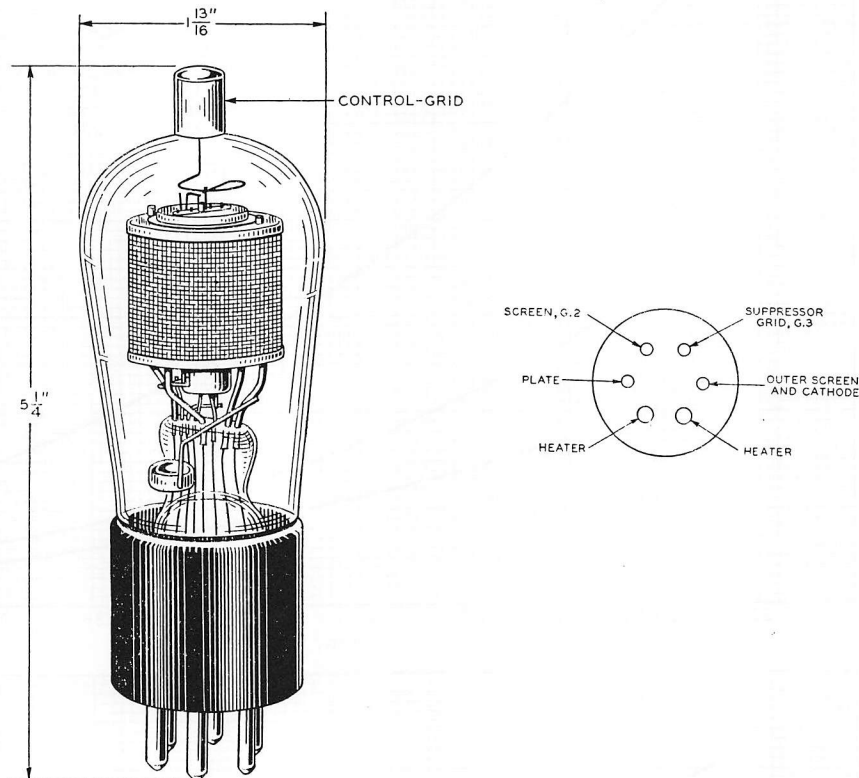

### Classification

The 286A Vacuum Tube is a variable-mu, triple-grid, tube having an indirectly heated cathode which permits operation of the heater element directly on alternating current. Primarily, the tube is intended for use as a high-frequency amplifier, with the outer grid connected to the cathode and serving as a suppressor. It may also be used as an audio-frequency amplifier or as a modulator.

### Base and Socket

The 286A Vacuum Tube employs a standard six prong base suitable for use in a Western Electric 144A or similar type socket. The arrangement of electrode connections to the base terminals is shown above. The control-grid terminal is located at the top of the bulb and is arranged for a special quick-release connector.

### Rating and Characteristic Data

Heater Voltage (A.C. or D.C.).....			2.0 Volts
Heater Current.....			1.6 Amperes
Plate Voltage.....	135	180	250 Max. Volts
Screen-Grid Voltage.....	75	75	75 Volts
Suppressor-Grid Voltage.....	0	0	0
For —1.5 Volts Control-Grid Bias			
Average Plate Current.....	6.1	6.2	6.3 Milliamperes
Average Plate Resistance.....	400,000	700,000	1,050,000 Ohms
Average Amplification Factor..	475	850	1,275
Average Mutual Conductance..	1,190	1,200	1,210 Micromhos
Average Control-Grid Bias for 5 Micromhos Mutual Conductance.....	—45	—45	—45 Volts
Approximate Direct Interelectrode Capacities (measured without socket)			
Plate to Control-Grid.....			0.004 MMF.
Control-Grid to Heater, Cathode, Screen-Grid and Suppressor-Grid.....			6.0 MMF.
Plate to Heater, Cathode, Screen-Grid and Suppressor-Grid.			14.0 MMF.

### Average Static Characteristics

The accompanying curves give the average static characteristics of the 286A Vacuum Tube.

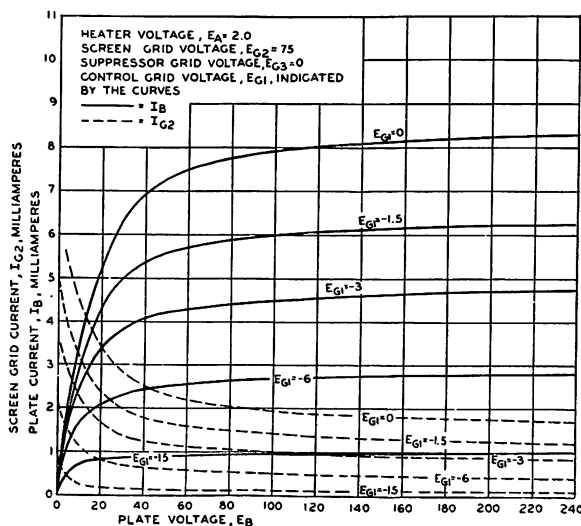

### General Features

The low plate to control-grid capacity of this tube makes unnecessary the use of neutralization for prevention of oscillation or feed-back, provided the rest of the circuit elements are properly shielded.

The variable-mu feature of this tube tends to prevent excessive cross-modulation and modulation-distortion as the amplification is varied by varying the control-grid bias. The tube is thus especially suitable for use in circuits employing automatic volume control.

A separate base terminal is provided for the suppressor grid making possible the use of the tube in various special circuits requiring application of either fixed or varying voltages on this element.

The cathode is designed to provide a very large electron emission compared with the current drain, thus assuring the maintenance of uniform characteristics over a long life.

## *Western Electric*

### 286A Vacuum Tube

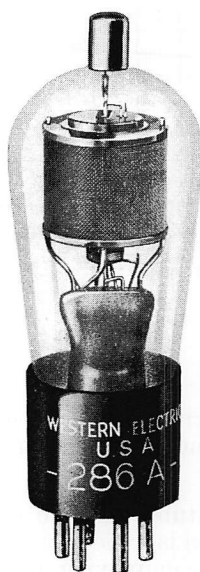

**Classification**—Variable- $\mu$ , voltage-amplifier, suppressor-grid pentode with indirectly heated cathode

Each of the three grids of the 286A tube is connected to a separate terminal.

#### **Applications**

High-frequency voltage amplifier, especially in circuits in which the amplification is varied by changing the control-grid bias.

Audio-frequency voltage amplifier.

Shielded modulator.

**Dimensions**—Dimensions, outline diagrams of the tube and base, and the arrangement of the electrode connections to the base terminals are shown in Figures 1 and 2.

**Base**—Medium, six-pin base. Small, metal cap control-grid terminal at the top of the bulb.

**Socket**—Standard, six-contact type, such as the Western Electric 144B socket.

**Mounting Positions**—The 286A tube may be mounted in any position.

### Average Direct Interelectrode Capacitances

Control grid to plate. . . . .	0.004 $\mu\mu\text{f.}$
Suppressor grid to plate. . . . .	1.7 $\mu\mu\text{f.}$
Plate to heater, cathode and screen grid. . . . .	12.2 $\mu\mu\text{f.}$
Control grid to suppressor grid. . . . .	0.06 $\mu\mu\text{f.}$
Control grid to heater, cathode and screen grid. . . . .	6.3 $\mu\mu\text{f.}$
Suppressor grid to heater, cathode and screen grid. . . . .	7.0 $\mu\mu\text{f.}$

### Heater Rating

Heater voltage. . . . .	2.0 volts, a.c. or d.c.
Nominal heater current. . . . .	1.60 amperes

The heater element of this tube is designed to operate on a voltage basis and should be operated at as near the rated voltage as is practicable.

**Cathode Connection**—Preferably direct to the heater. If voltage must be applied between the cathode and heater, it should be kept as low as possible and should never exceed 90 volts.

**Characteristics**—Plate current and screen-grid current characteristics of a typical 286A tube are given in Figures 3 and 4, respectively, as functions of plate voltage for a screen-grid voltage of 75 volts, zero suppressor-grid voltage, and several values of control-grid voltage. A typical characteristic showing plate current as a function of control-grid voltage is given in Figure 5 for a plate voltage of 180 volts, a screen-grid voltage of 75 volts, and zero suppressor-grid voltage. The corresponding transconductance characteristic is shown in Figure 6. For other plate voltages between 135 and 250 volts, the transconductance of a typical tube for values higher than 5 micro-mhos does not differ by more than  $\pm 2$  per cent from its value at 180 volts. Amplification factor and plate resistance characteristics are shown in Figures 7 and 8, respectively, as functions of control-grid voltage for a screen-grid voltage of 75 volts, zero suppressor-grid voltage, and several values of plate voltage. Plate current and screen-grid current characteristics are shown in Figures 9 and 10 as functions of plate voltage for a screen-grid voltage of 75 volts, a control-grid voltage of  $-1.5$  volts, and several values of suppressor-grid voltage. Corresponding amplification factor, plate resistance, and transconductance characteristics are given in Figures 11, 12, and 13, respectively.

### Typical Operating Conditions

Plate Voltage Volts	Screen-Grid Voltage Volts	Suppressor-Grid Voltage Volts	Control-Grid Bias Volts	Plate Current Milli-amperes	Screen-Grid Current Milli-amperes	Amplification Factor	Plate Resistance Ohms	Trans-conductance Micro-mhos
135	75	0	$-1.5$	6.1	1.7	475	400,000	1190
180	75	0	$-1.5$	6.2	1.6	850	700,000	1200
*250	75	0	$-1.5$	6.3	1.5	1275	1,050,000	1210
**135-250	75	0	$-45$	—	—	—	—	5

\*Maximum operating conditions

\*\*Nominal cut-off

Less severe operating conditions should be selected in preference to maximum operating conditions wherever possible. The life of the tube at maximum conditions may be shorter than at less severe conditions.

**Microphonic Noise**—With a plate voltage of 180 volts, a screen-grid voltage of 75 volts, zero suppressor-grid voltage, a control-grid voltage of  $-1.5$  volts, and a load resistance of 100,000 ohms, the mean microphonic noise output level of the 286A tube, measured in a laboratory reference test set, is 17 db below 1 volt. The range of levels of individual tubes extends from 0 to 34 db below 1 volt. Since microphonic noise level depends on the type and intensity of the mechanical disturbance which produces it, the values given here are useful chiefly for comparison with the levels of other types of tubes which have been tested in the same way.

**Special Features**—By virtue of its variable- $\mu$  characteristic, the 286A tube is particularly well adapted to amplifier or modulator applications where the sensitivity is controlled by varying the grid bias. As the control grid is made more negative, the transconductance and plate current approach zero gradually rather than sharply, so that distortion is relatively small at all values of grid bias.

In addition to its amplifier applications, the tube is also effective as a shielded modulator. Due to the low capacitance between the first and third grids, separate inputs may be applied to these elements without appreciable interaction. Both of these grids are negative for such use, so that the power required to drive them is negligible. The operating conditions suggested in the table on page 2 are appropriate except that a negative bias numerically equal to about  $\frac{1}{8}$  of the plate voltage should be applied to the suppressor grid.

**Circuit Requirements**—In order to make use of the high gain per stage of which the 286A tube is capable when used as a voltage amplifier, suitable precautions must be taken, especially where high frequencies are involved, to avoid undesired feed-back in the circuit. It is usually necessary to use a close-fitting shield around each tube, to shield each stage of the amplifier circuit, to connect a low-impedance condenser between each screen-grid and its corresponding cathode, to filter each battery lead to each tube, and to avoid impedances common to the plate, screen-grid, control-grid, or cathode circuits of two or more tubes. For amplifier applications, each suppressor grid should be connected directly to its corresponding cathode.

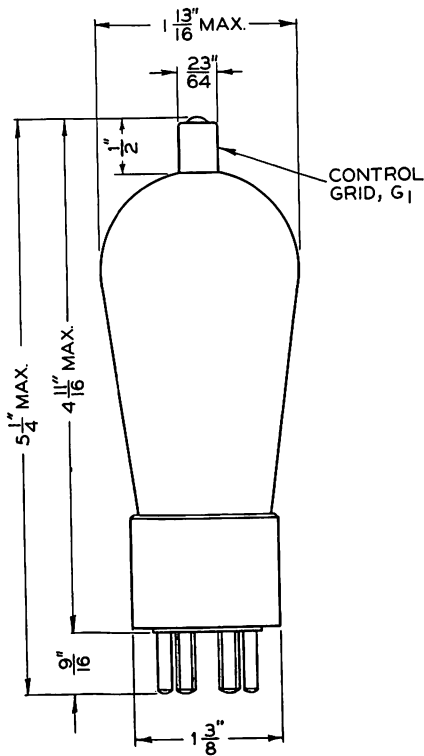

FIG. 1

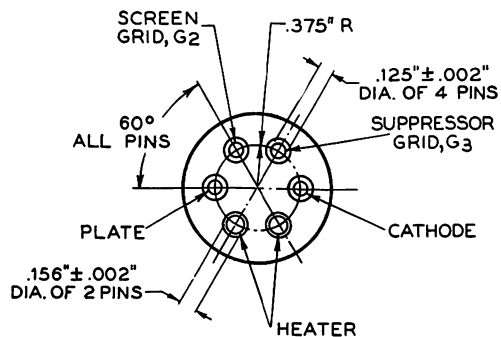

FIG. 2

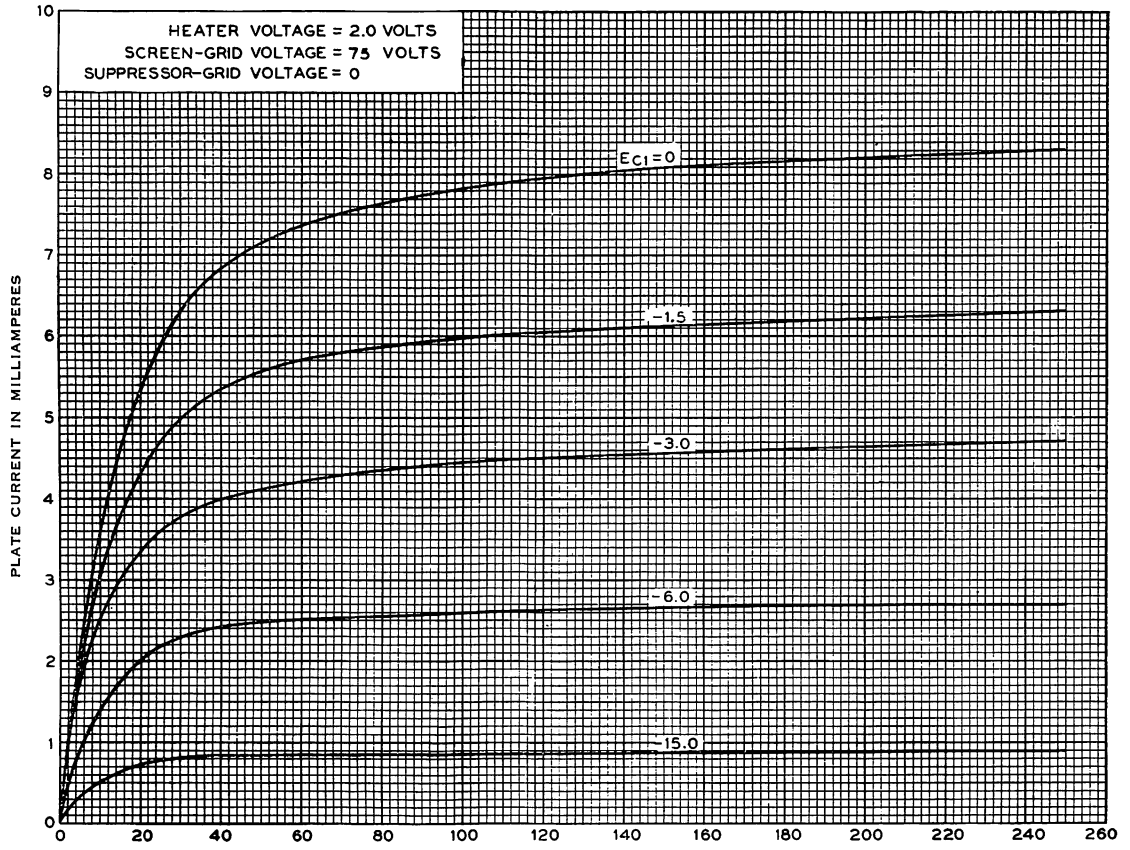

FIG. 3

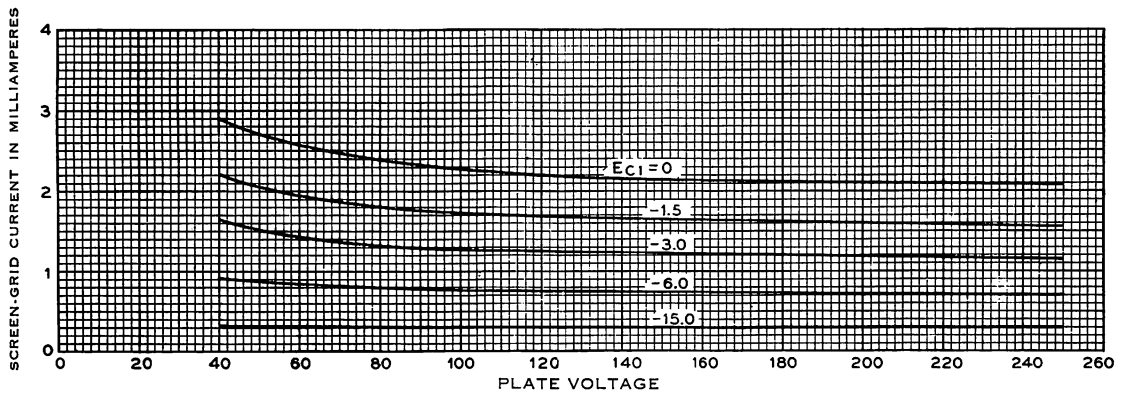
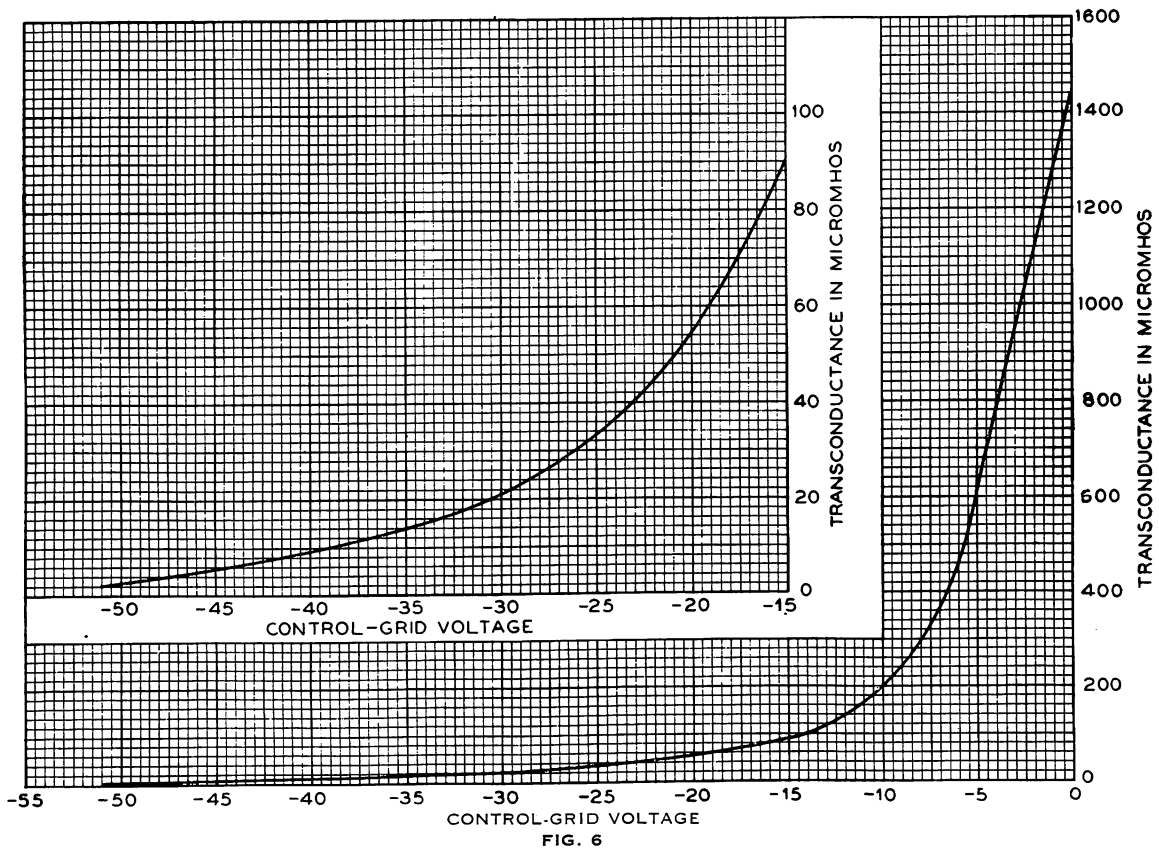
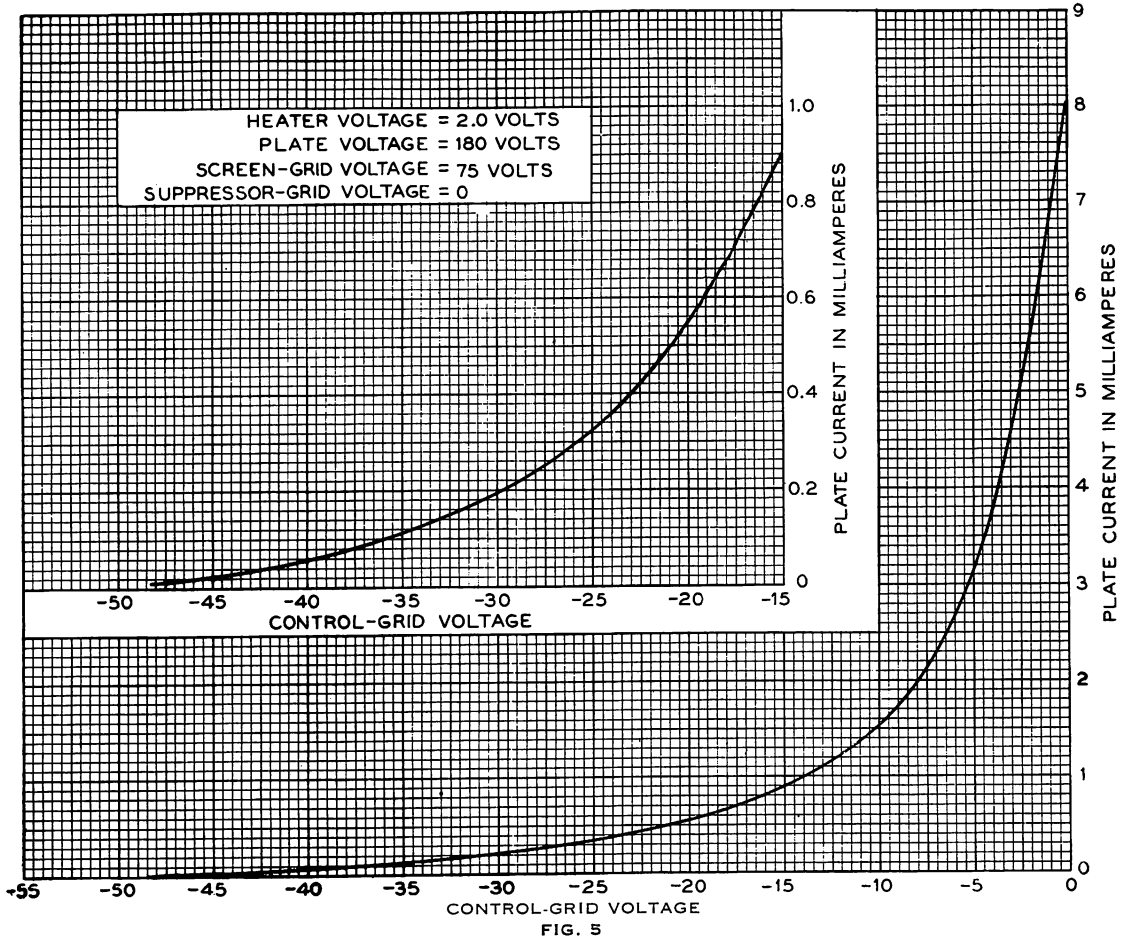

FIG. 4



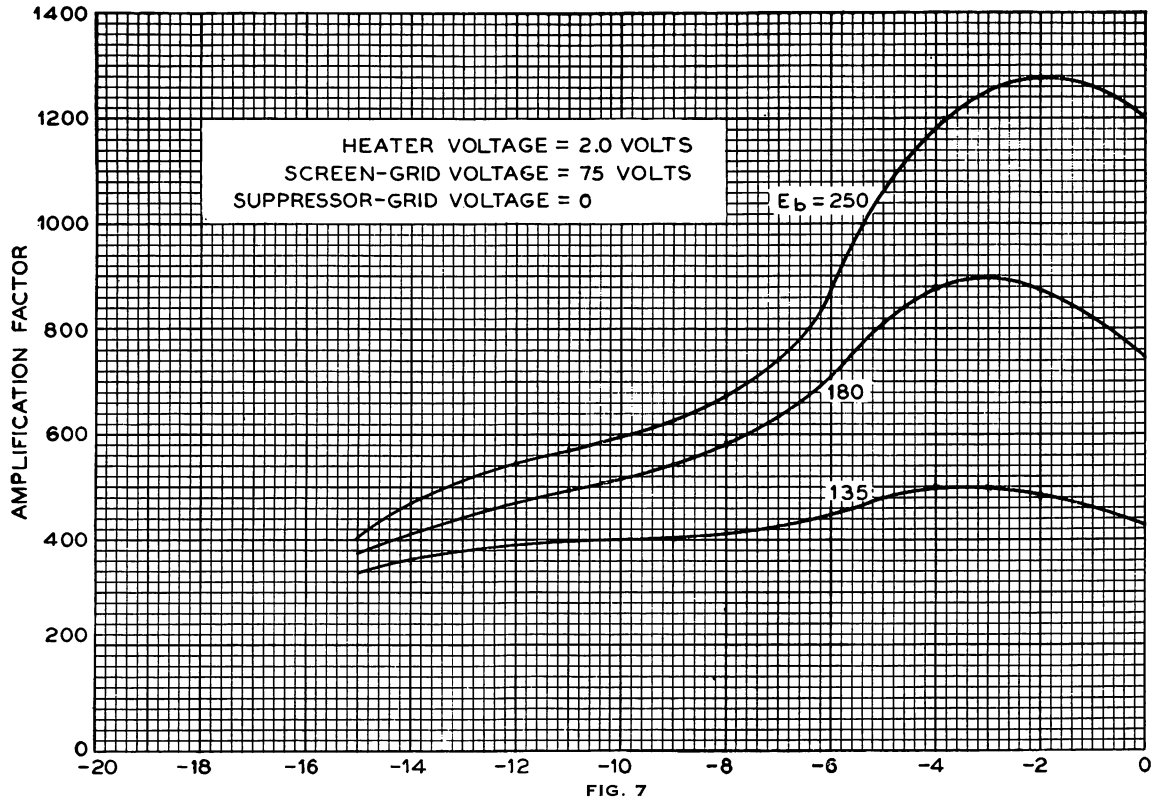

FIG. 7

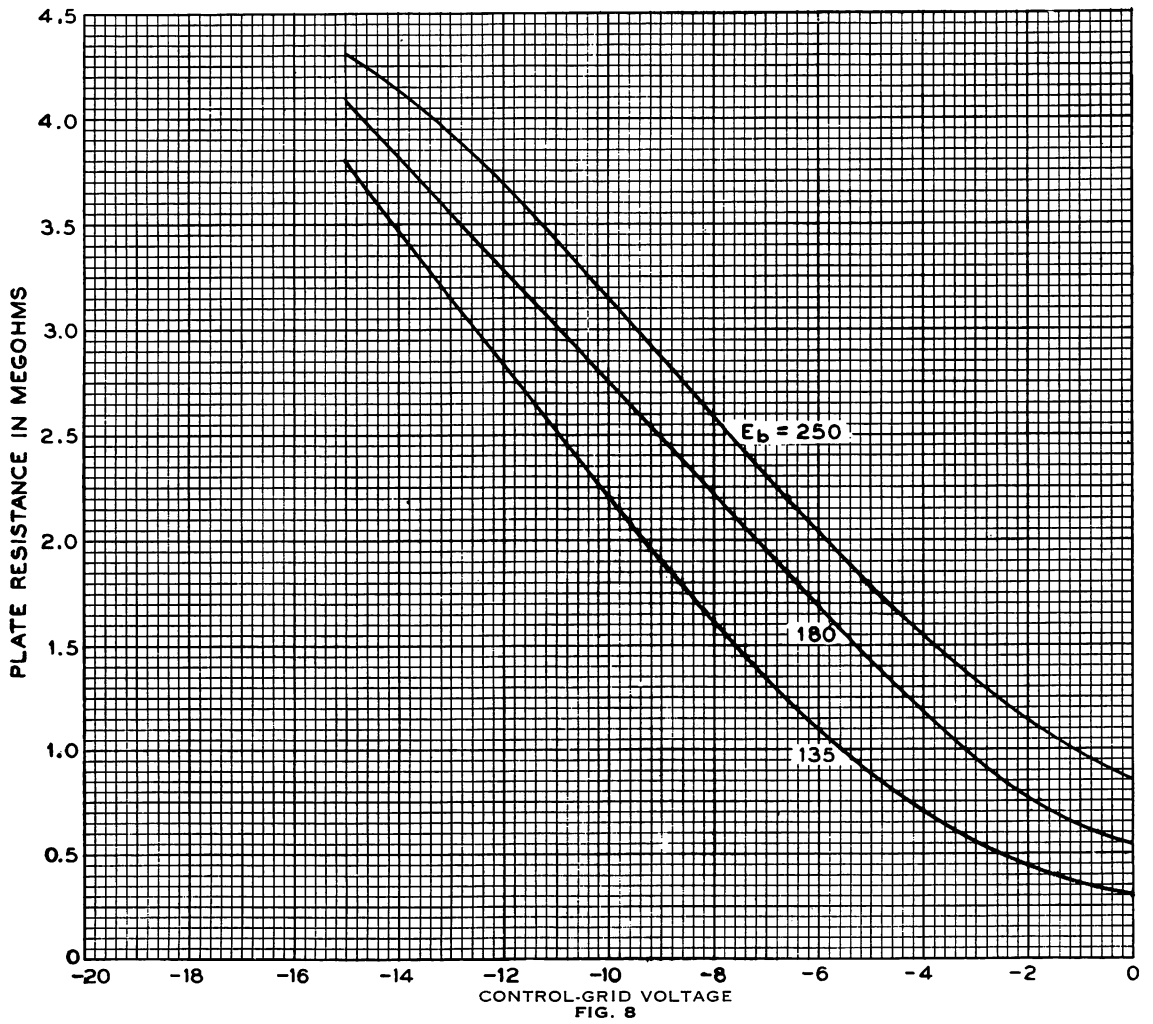

FIG. 8



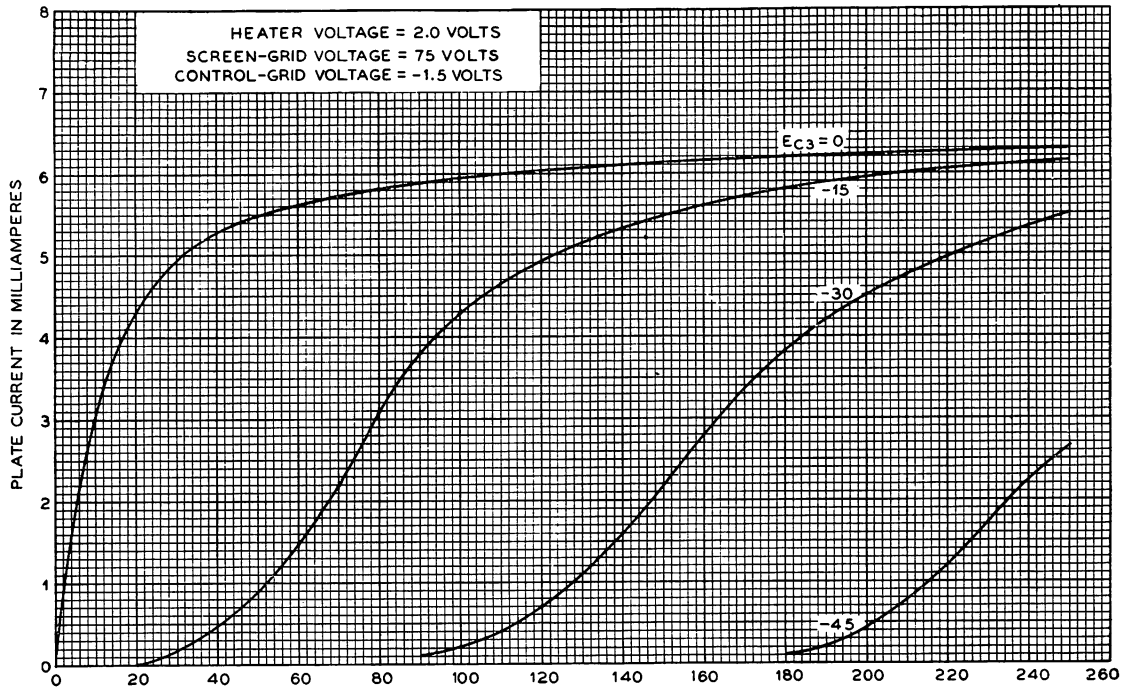

FIG. 9

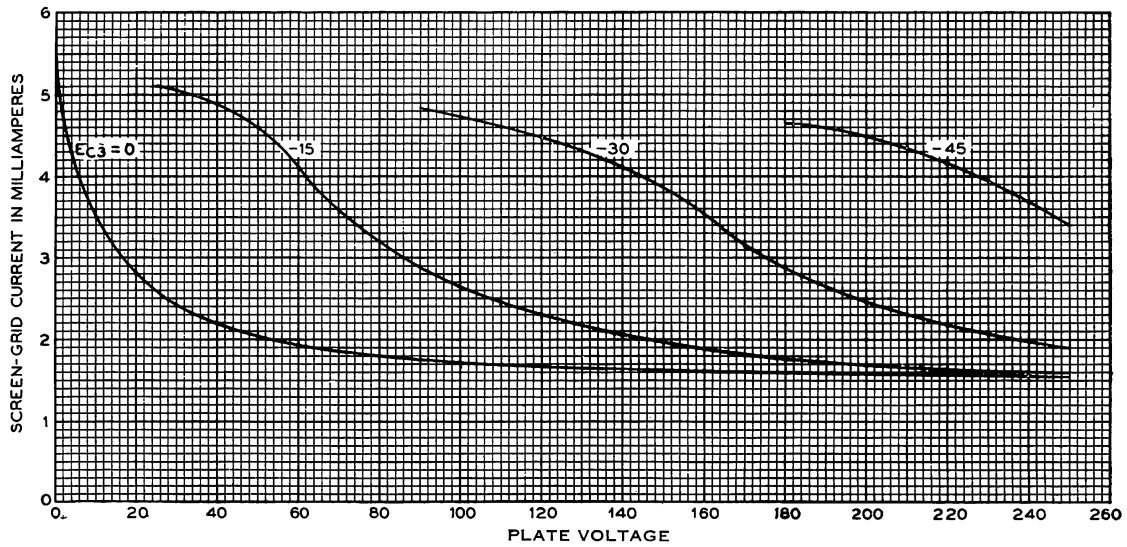

FIG. 10

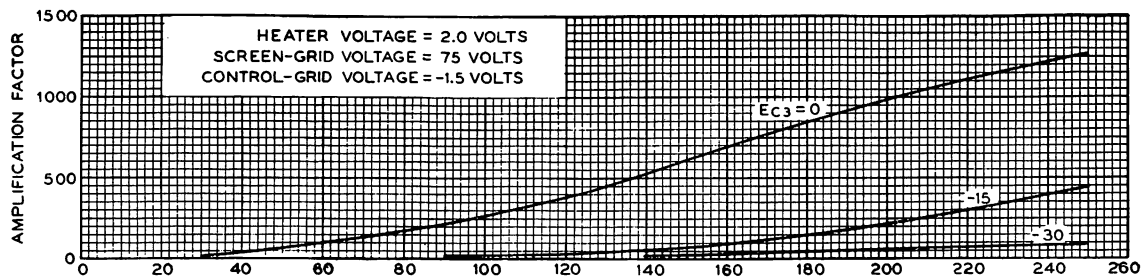

FIG. 11

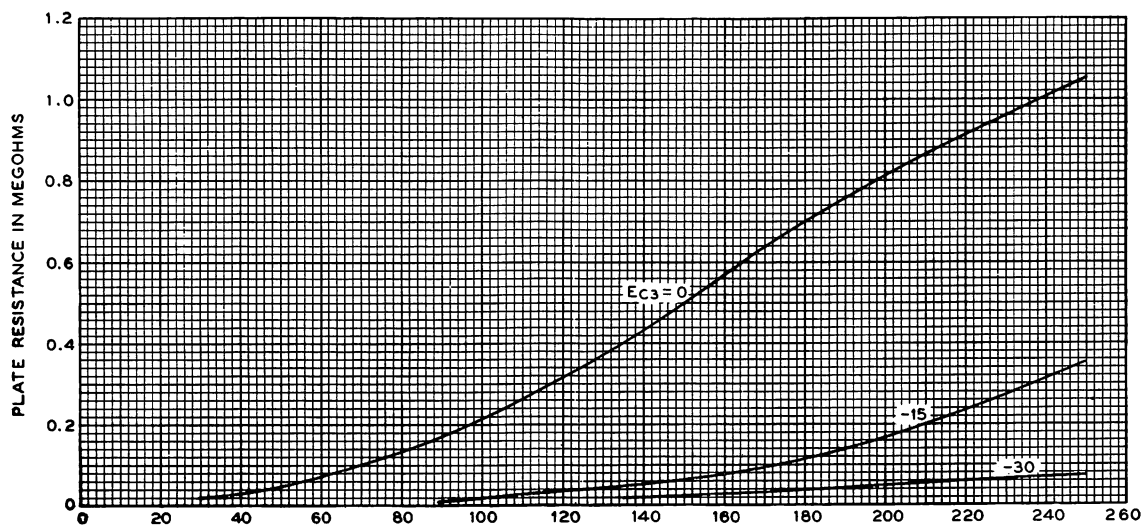

FIG. 12

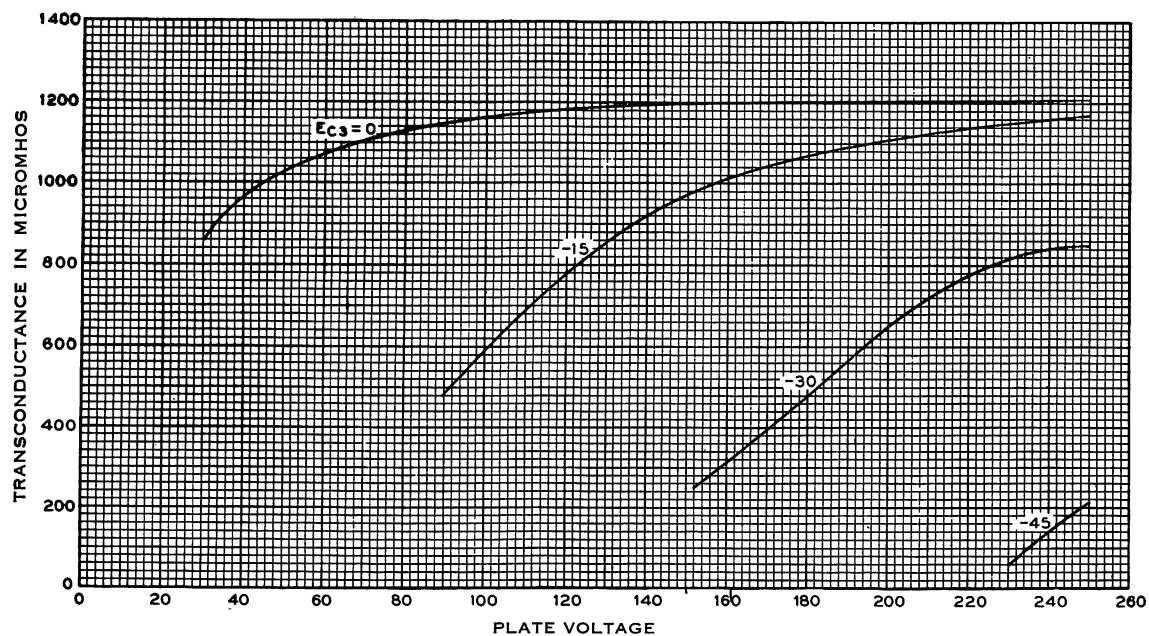

FIG. 13