

**RECTIFIER  
HALF-WAVE, MERCURY-VAPOR**

*Western Electric*

**DESCRIPTION**

The 266B is a half-wave, mercury-vapor rectifier tube for use in high-voltage rectifier circuits.

**MAXIMUM RATINGS**

Peak Inverse Anode Voltage	22000 volts
Average Cathode Current (Quadrature Operation)	10 amperes

**MAXIMUM RATINGS, ABSOLUTE VALUES**

Peak Inverse Anode Voltage for		
Condensed Mercury Temperature 20 to 40 C	.....	22000 volts
Condensed Mercury Temperature 20 to 50 C	.....	12500 volts
Cathode Current		
Peak		
In-phase Operation	.....	20 amperes
Quadrature Operation	.....	40 amperes
Average		
In-phase Operation	.....	5 amperes
Quadrature Operation	.....	10 amperes
Surge (maximum duration 0.2 second)	.....	200 amperes
Averaging Time	.....	60 seconds
Frequency	.....	150 cycles/sec.

<b>ELECTRICAL DATA</b>	Min.	Bogey	Max.
Filament Voltage	4.75	5.0	5.25 volts
Filament Current at 5.0 Volts	.....	42	46 amperes
Cathode Heating Time, Required	300	.....	..... seconds
Anode Voltage Drop	.....	15	..... volts
Critical Anode Voltage	.....	.....	100 volts

**MECHANICAL DATA**

Net Weight, Approximate	.....	4¼ pounds
Equilibrium Condensed Mercury Temperature Rise		
At Full Load, Approximate	.....	18 centigrade
At No Load, Approximate	.....	15 centigrade

**Cooling**      The condensed mercury temperature should be held within the range specified for the maximum peak inverse anode voltage appropriate to the application. If forced-air cooling is necessary, a flow of 6 cubic feet per minute from a 1-inch nozzle directed at the zone of mercury temperature control just below the support collar ordinarily will be adequate.

**Mounting**      This tube has a collar at the filament end of the tube by which it is supported when mounted. It should be mounted in a vertical position only, with the filament end down. Connections to the anode and filament terminals should be flexible. Sufficient clearance should be maintained around the tube to insure free air circulation.

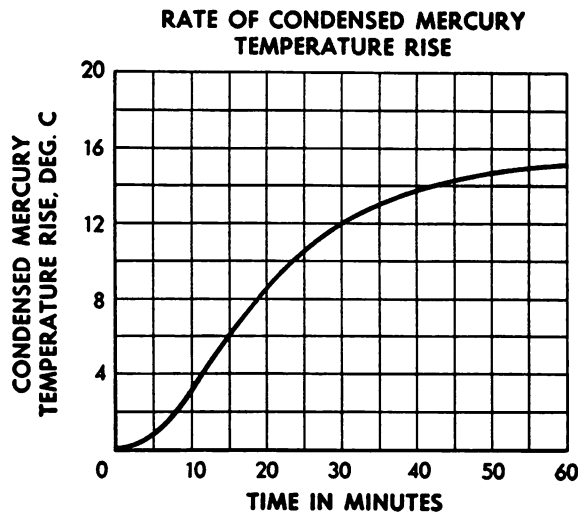

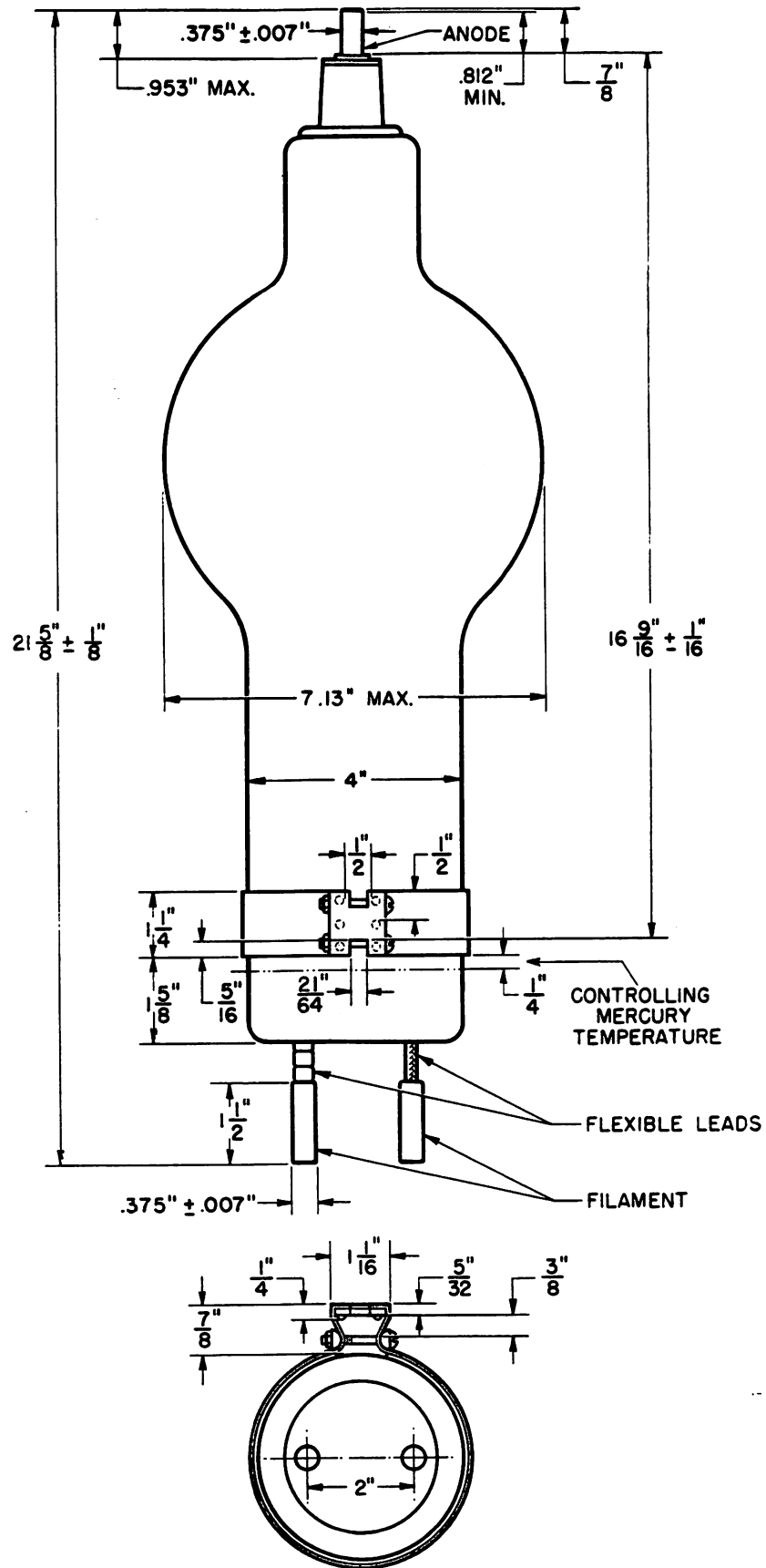

# Western Electric

## Vacuum Tubes

### Half-Wave Mercury Vapor Rectifiers

249B  
253A

255B  
258B

266B  
266C

267B  
315A

319A  
321A

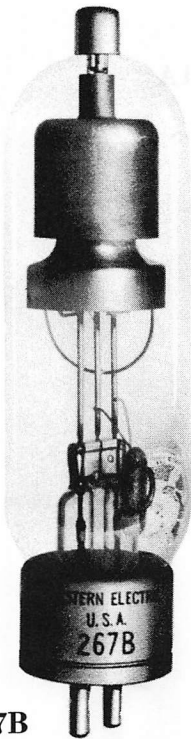

267B

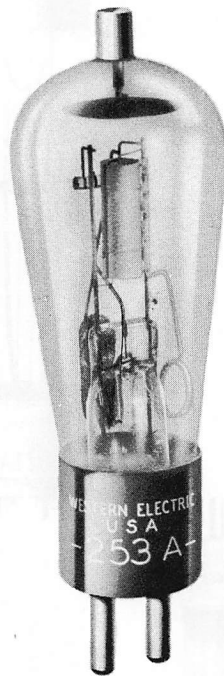

253A

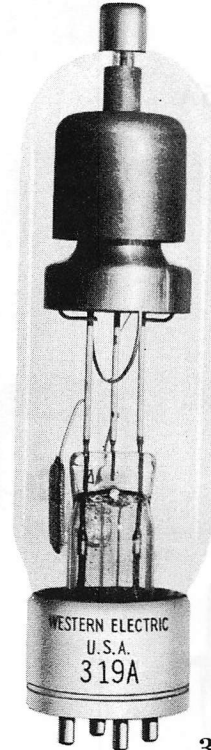

319A



249B



258B

#### NOTE:

This combined bulletin supersedes data sheets previously issued for the individual tubes.

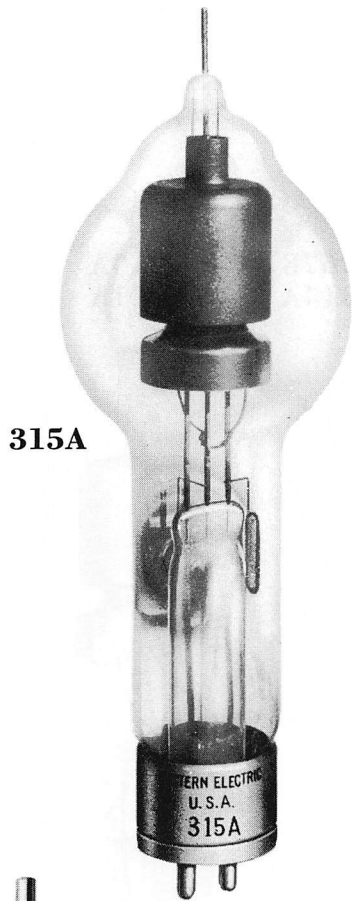

315A

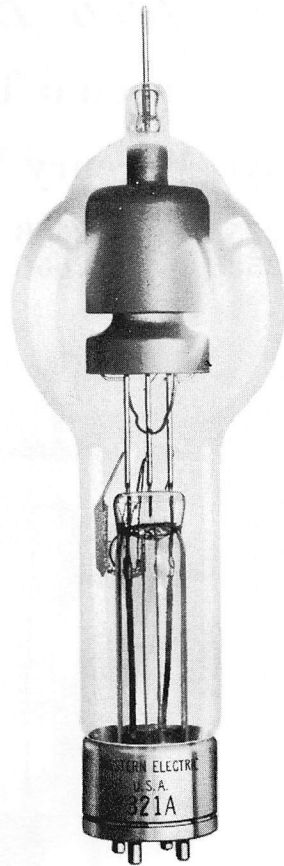

321A

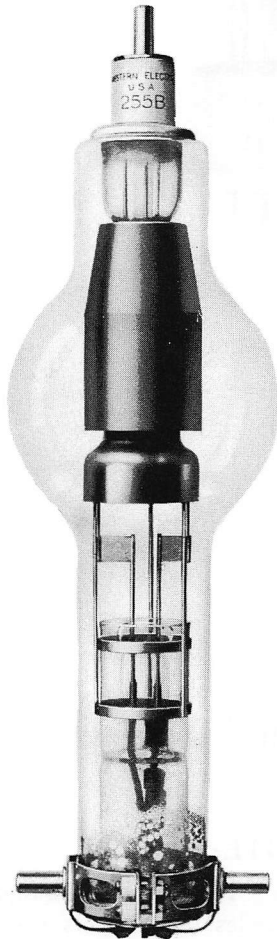

255B

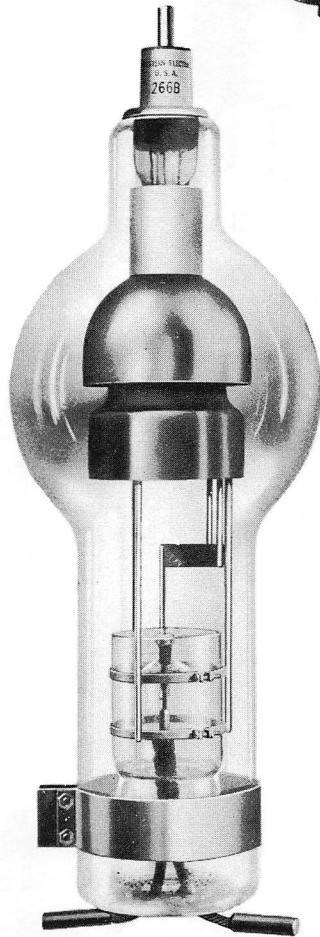

266B

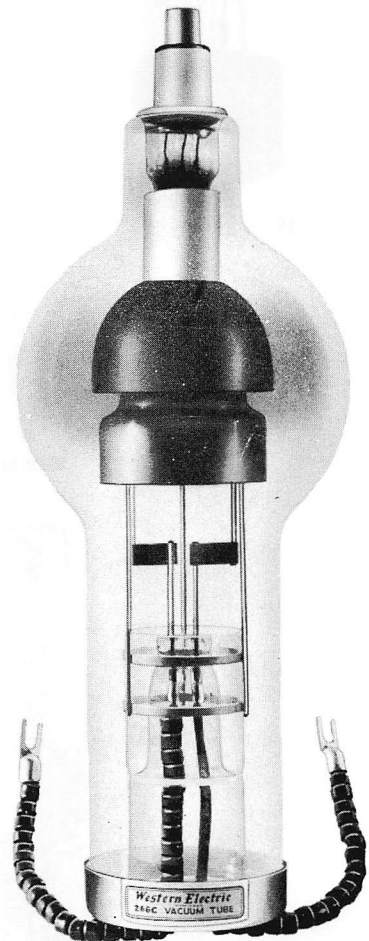

266C

---

## **Classification**

These tubes are half-wave, thermionic, mercury vapor rectifiers designed to supply direct-current from an alternating-current supply.

**Mounting**—The tubes should be mounted only in a vertical position with the base or filament end down. Free air circulation must be provided. No object should touch the glass bulb.

**Filament**—The filaments are designed to operate from alternating current sources. The voltage should be maintained to within 5% of the rated value. Operation of the filaments at a voltage above the upper limit will definitely reduce the life of the tubes while a decrease in voltage below the lower limit may cause immediate failure.

## **Normal Filament Heating**

The anode voltage should not be applied until the filaments have reached a satisfactory operating temperature. When normal filament voltage and circuits with good regulation are used, the minimum time required is specified on the individual tube data sheet as the “Required Heating Time.” It is also necessary to allow sufficient filament heating time to evaporate any visible mercury deposits from the upper parts of the tubes.

When the tubes are put into operation at low ambient temperatures, an extended filament heating time is necessary to raise the mercury vapor pressure to a satisfactory operating value. This time is given in graph form on the individual tube data sheet for tubes requiring such heating when operating within the recommended ambient temperature range. A filament heating period of 30 minutes or more should be allowed when the tubes are used for the first time or if they have been subjected to extensive handling or prolonged standing.

## **Accelerated Filament Heating**

In certain applications it may be desirable to reduce the “Required Heating Time” designated for normal filament voltage. This may be accomplished by applying an overvoltage to the filament for a short period after which the rated filament voltage and the anode voltage is applied. The recommended open circuit overvoltage and the corresponding period of application are given on the individual tube data sheet. These ratings apply when the regulation of the filament supply circuit is  $10\% \pm 4\%$ .

## **Tube Voltage Drop**

The tube voltage drop is substantially independent of the anode current. The exact value varies but under the specified operating conditions will normally be between 5 and 25 volts.

## **Maximum Anode Current**

The maximum permissible instantaneous and average anode current ratings are limitations on the current values that the tubes can carry safely in the direction in which they are designed to conduct and should not be exceeded. The current ratings specified under “In-phase Operation” apply when the filament and anode voltages are in phase, or where the relative phase angle is ignored. The “Quadrature Operation” ratings may be used when the circuit is designed so that the phase angle between the filament and anode voltage is approximately 90 electrical degrees. With this type of operation, the filament current goes through zero near the center of the anode conduction period, resulting in a balanced operating condition for the filament, which permits the higher anode currents.

## **Maximum Peak Inverse Anode Voltage**

The maximum permissible peak inverse anode voltage is a limitation on the instantaneous value that the tubes can stand safely in the opposite direction to that in which they are designed to conduct. If this voltage is exceeded an arc-back may result which may injure the tubes. The maximum direct output voltage available is not fixed but will depend upon the type of circuit used.

Tubes of the same type may be operated in parallel if some provision is made to insure a proper division of the load current. Current dividing reactors or ballasting resistors in series with each anode may be used for this purpose. The size of the reactors or resistors will depend upon the circuit design.

In most cases the termination of useful life of these tubes is due to the loss of filament activity which frequently results in arc-back. Failures of this kind should be safeguarded by proper overload protection to prevent injury to other tubes in the set and to auxiliary equipment. In most circuits this requires a quick acting high-voltage fuse in each anode lead or an equally fast primary fuse or circuit breaker.

**Circuits**

These tubes may be used in any conventional rectifier circuit subject to the current, voltage and temperature ratings. Typical circuits are shown below. The approximate direct output current and voltage for each type of rectifier circuit where tubes are operated at maximum permissible anode current and inverse voltage is given on the individual tube data sheet. The values listed are average values of the pulsating current and voltage for an unfiltered circuit.

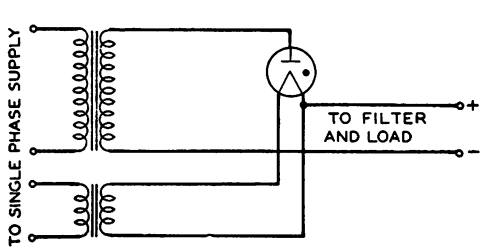

SINGLE PHASE, HALF-WAVE  
CIRCUIT A

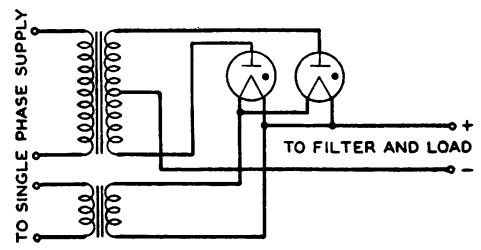

SINGLE PHASE, DOUBLE HALF-WAVE  
CIRCUIT B

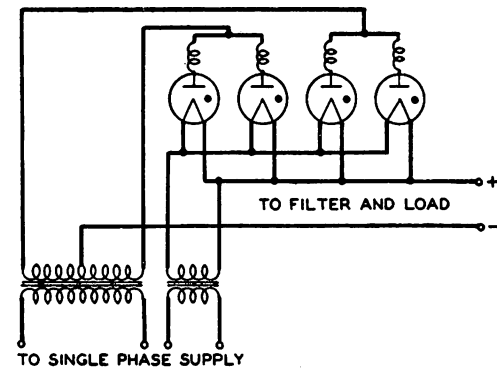

SINGLE PHASE, DOUBLE HALF-WAVE IN PARALLEL  
CIRCUIT C

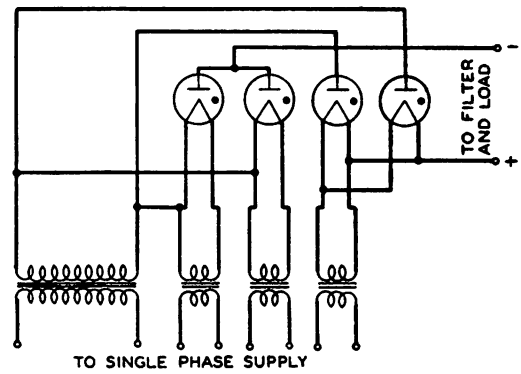

SINGLE PHASE, DOUBLE HALF-WAVE  
4 TUBE SERIES CIRCUIT  
CIRCUIT D

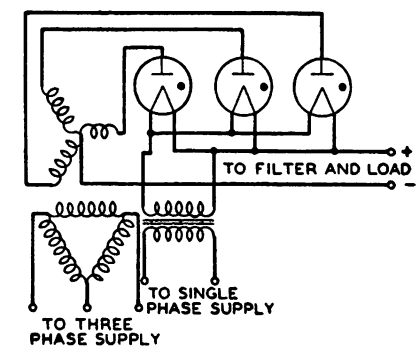

THREE PHASE Y CIRCUIT  
CIRCUIT E

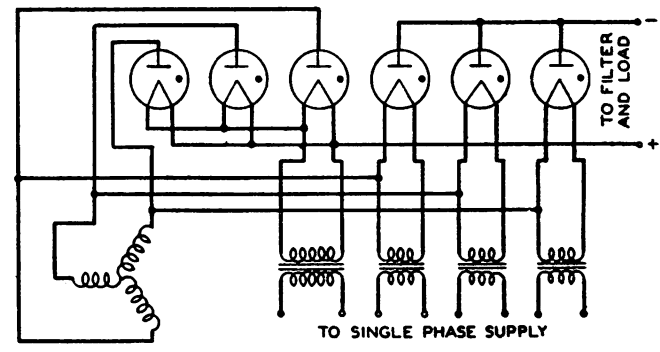

THREE PHASE, 6 TUBE SERIES CIRCUIT  
CIRCUIT F

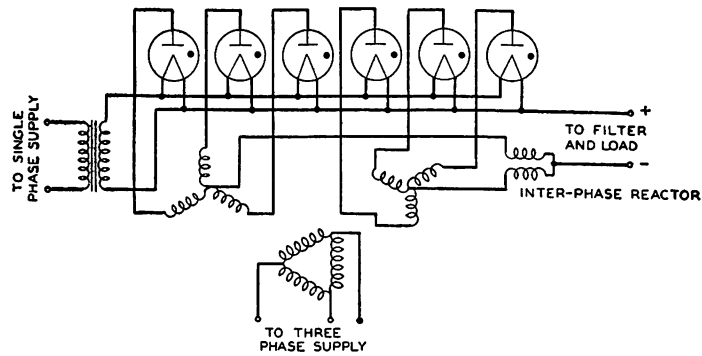

THREE PHASE, DOUBLE "Y" INTERCONNECTED  
CIRCUIT G

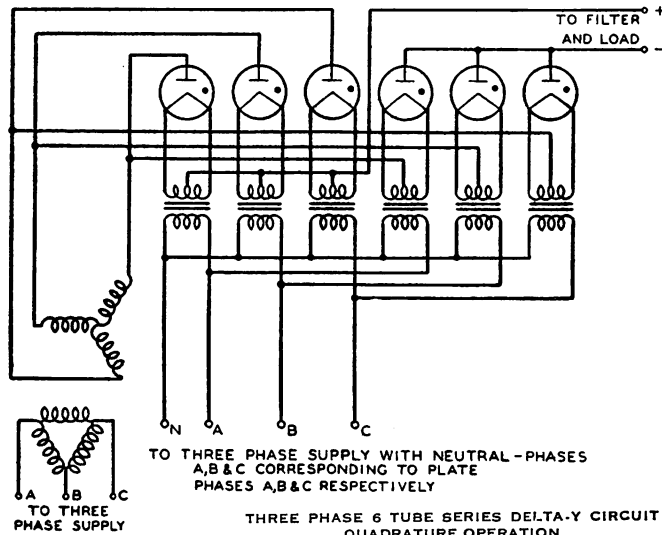

THREE PHASE 6 TUBE SERIES DELTA-Y CIRCUIT  
QUADRATURE OPERATION  
CIRCUIT H

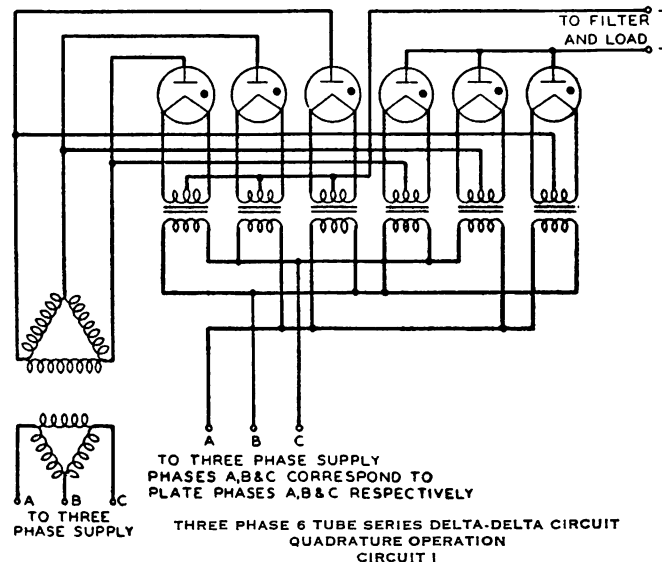

THREE PHASE 6 TUBE SERIES DELTA-DELTA CIRCUIT  
QUADRATURE OPERATION  
CIRCUIT I



## 249B and 258B Vacuum Tubes

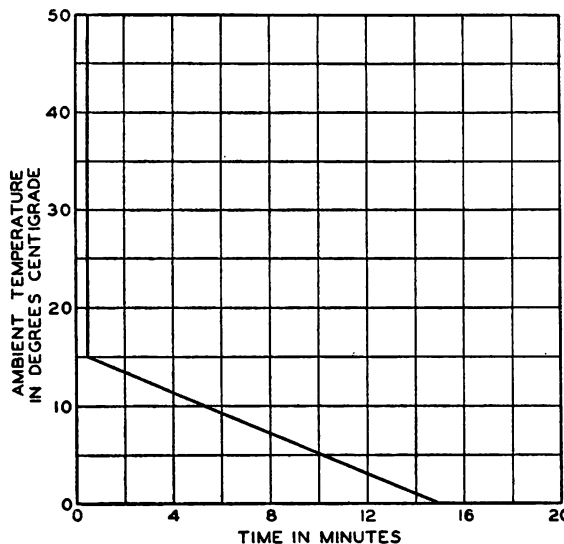
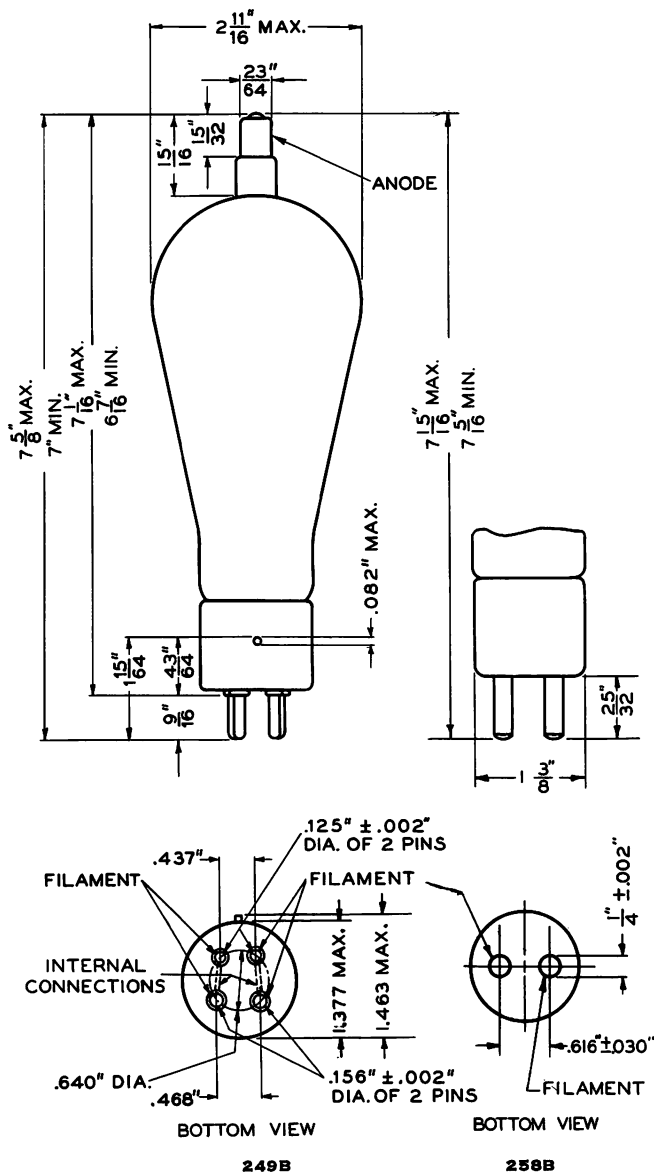

MINIMUM FILAMENT WARMING TIME VS. AMBIENT TEMPERATURE

CORRESPONDING AMBIENT TEMPERATURE IN DEGREES CENTIGRADE AFTER TEMPERATURE EQUILIBRIUM

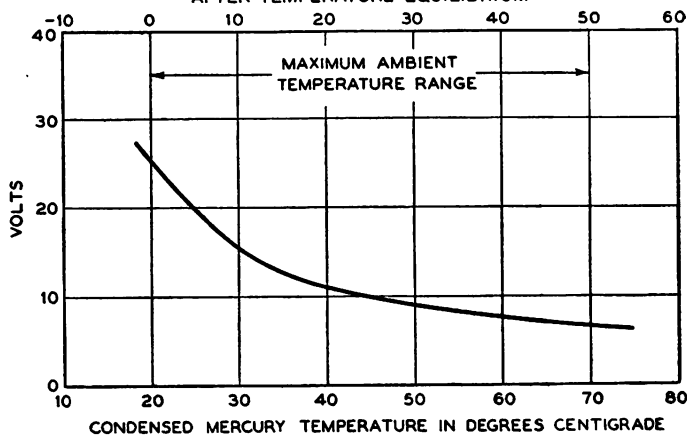

TUBE VOLTAGE DROP VS. TEMPERATURE FOR A TYPICAL TUBE

### Ratings

<b>Filament</b>	
Voltage	2.5 volts
Nominal Current	7.5 amperes
Required Heating Time	15 seconds
Accelerated Filament Heating	
Recommended open circuit over-voltage	50%
Corresponding period of over-voltage application	8 ± 2 seconds
Tube Voltage Drop—Approximate	15 volts
Maximum Instantaneous Anode Current	2.5 amperes
Maximum Average Anode Current	0.64 ampere
Max. Time of Averaging Anode Current	5 seconds
Maximum Peak Inverse Anode Voltage	7.5 kilovolts
Maximum Ambient Temperature Range	0 to 50°C.

**Mounting**—The 249B tube requires a W. E. 143B or similar socket and the 258B a W. E. 138B, 139A or similar socket. A spring clip anode terminal connector is required. Mount in vertical position only—base end down. A clearance of at least 2 inches should be allowed between the bulb and any adjacent object.

### Circuit Outputs:

Circuit Designation	Number of Tubes	Output Voltage Load Current	
		At 7.5 kv. Inverse Voltage	In DC Amperes
A	1	2300	0.64
B	2	2300	1.28
C	4	2300	2.56
D	4	4600	1.28
E	3	3500	1.92
F	6	7000	1.92
G	6	3000	3.2

# 253A Vacuum Tube

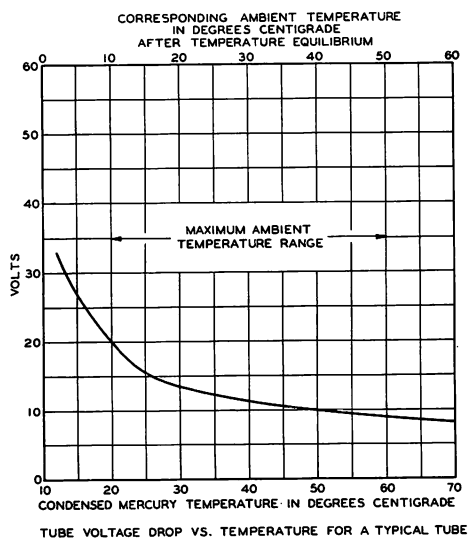
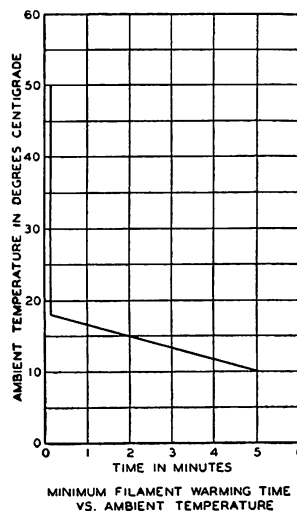
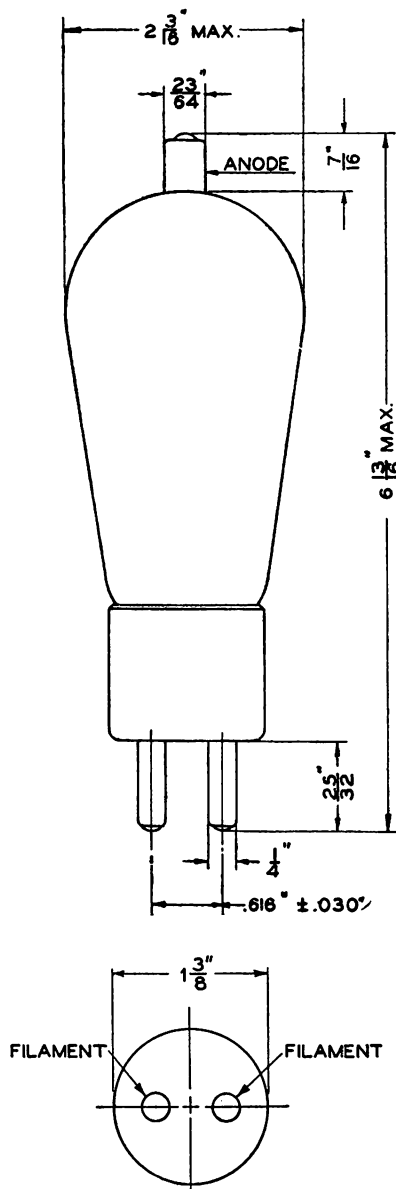

## Ratings

<b>Filament</b>	
Voltage	2.5 volts
Nominal Current	3.0 amperes
Required Heating Time	10 seconds
<b>Accelerated Filament Heating</b>	
Recommended open circuit over-voltage	50%
Corresponding period of over-voltage application	$6 \pm 2$ seconds
<b>Tube Voltage Drop—Approximate</b>	15 volts
<b>Maximum Instantaneous Anode Current</b>	1.0 ampere
<b>Maximum Average Anode Current</b>	0.25 ampere
<b>Max. Time of Averaging Anode Current</b>	5 seconds
<b>Maximum Peak Inverse Anode Voltage</b>	3500 volts
<b>Maximum Ambient Temperature Range</b>	10 to 50° C.

**Mounting**—W. E. 138B, 139A or similar socket. A spring clip anode terminal connector is required. Mount in vertical position only—base end down. A clearance of at least  $1 \frac{1}{2}$  inches should be allowed between the bulb and any adjacent object.

## Circuit Outputs:

Circuit Designation	Number of Tubes	Output Voltage	Load Current
		At 3500 volts Inverse Voltage	In DC Amperes
A	1	1000	0.25
B	2	1000	0.50
C	4	1000	1.00
D	4	2000	0.50
E	3	1500	0.75
F	6	3000	0.75
G	6	1400	1.25

## 255B Vacuum Tube

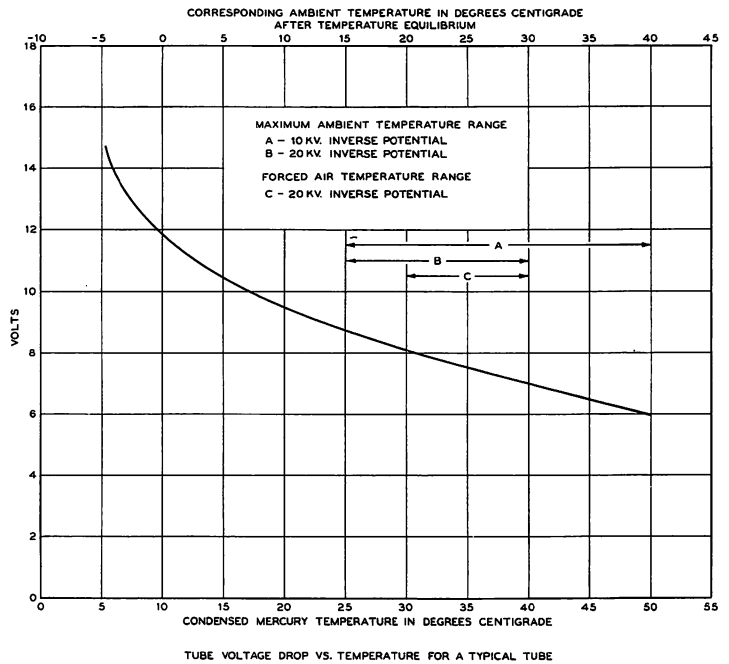
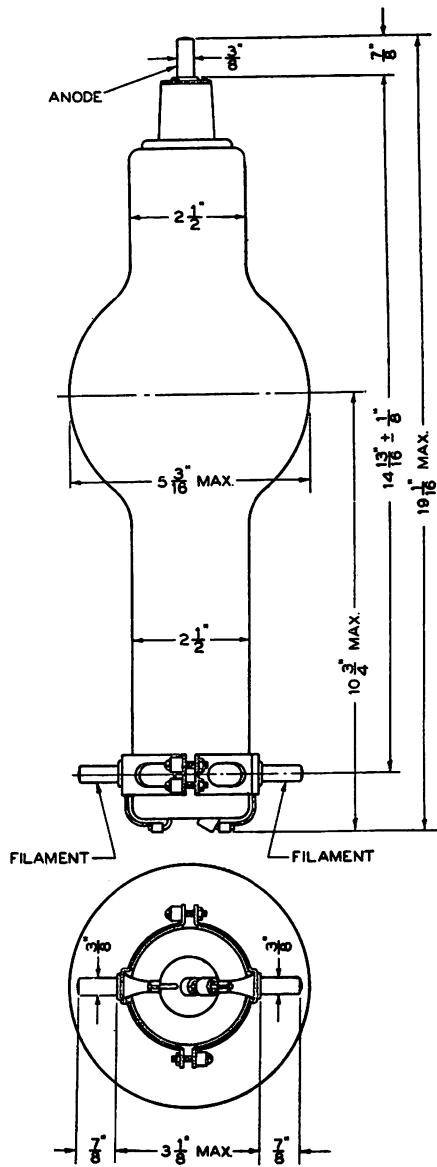

### Maximum Peak Inverse Anode Voltage

at 15 to 30° C. ambient temperature	20 kilovolts
at 15 to 40° C. ambient temperature	10 kilovolts
at 30 to 40° C. forced air temperature	20 kilovolts

This is the temperature of the forced air applied to the bulb where the free mercury condenses. Approximately 6 cu. ft. per minute from a 1 inch nozzle and directed just above the support collar is recommended.

**Mounting**—Special mounting is required. Mount in vertical position only—filament end down. A clearance of at least 4 inches should be allowed between the bulb and any adjacent object. Connection to the anode terminal should be semi-flexible.

### ratings

<b>Filament</b>	
Voltage	5.0 volts
Nominal Current	19.0 amperes
Required Heating Time	120 seconds
Accelerated Filament Heating	
Recommended open circuit over-voltage	50%
Corresponding period of over-voltage application	25 ± 5 seconds
Tube Voltage Drop—Approximate	10 volts
Maximum Instantaneous Anode Current	
In-Phase Operation	8 amperes
Quadrature Operation	16 amperes
Maximum Average Anode Current	
In-Phase Operation	2 amperes
Quadrature Operation	4 amperes
Max. Time of Averaging Anode Current	30 seconds

### Circuit Outputs:

Circuit Designation	Number of Tubes	Output Voltage		Load Current—DC Amps.	
		At 10 kv. Inverse Voltage	At 20 kv. Inverse Voltage	In-Phase Operation	Quadrature Operation
A	1	3000	6000	2	4
B	2	3000	6000	4	8
C	4	3000	6000	8	16
D	4	6000	12000	4	8
E	3	4500	9000	6	12
F	6	9000	18000	6	—
G	6	4000	8000	10	20
H	6	9000	18000	—	12
I	6	9000	18000	—	12

# 266B Vacuum Tube

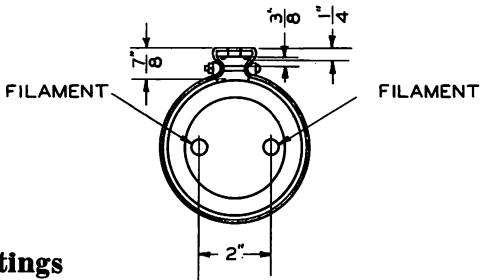
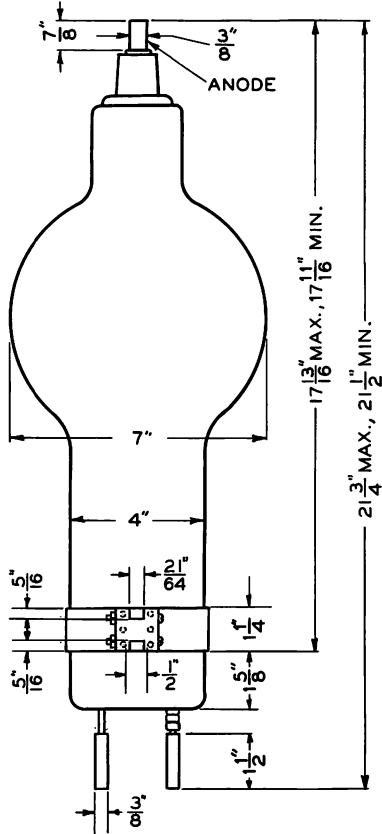

### Ratings

<b>Filament</b>	
Voltage	5.0 volts
Nominal Current	42.0 amperes
Required Heating Time	300 seconds
Accelerated Filament Heating	
Recommended open circuit over-voltage	50%
Corresponding period of over-voltage application	30 ± 5 seconds
Tube Voltage Drop—Approximate	15 volts
Maximum Instantaneous Anode Current	
In-Phase Operation	20 amperes
Quadrature Operation	40 amperes
Maximum Average Anode Current	
In-Phase Operation	5 amperes
Quadrature Operation	10 amperes
Max. Time of Averaging Anode Current	60 seconds
Maximum Peak Inverse Anode Voltage	
at 15 to 30° C. ambient temperature	20 kilovolts
at 15 to 40° C. ambient temperature	10 kilovolts
at 30 to 40° C. forced air temperature	20 kilovolts

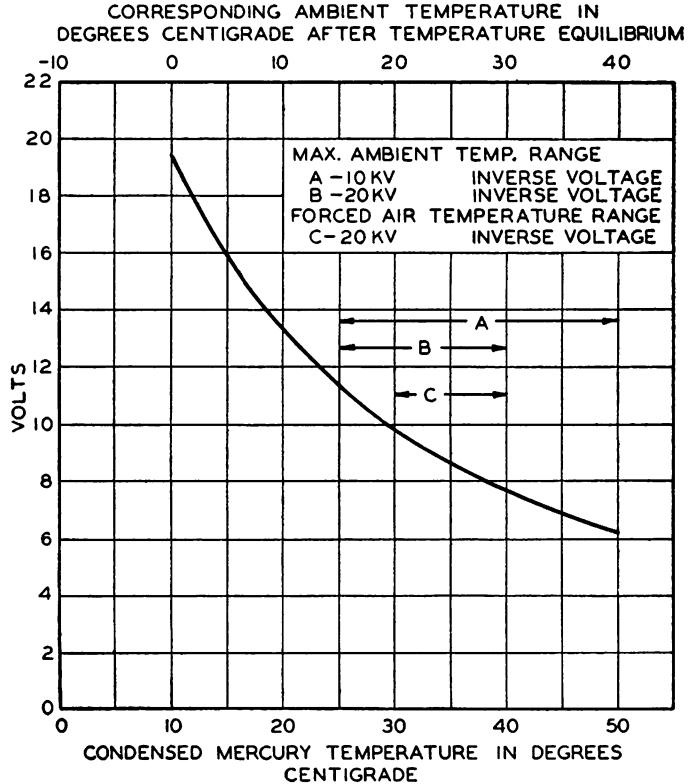

TUBE VOLTAGE DROP VS. TEMPERATURE FOR A TYPICAL TUBE

This is the temperature of the forced air applied to the bulb where the free mercury condenses. Approximately 8 cu. ft. per minute from a 1 inch nozzle and directed just below the support collar is recommended.

**Mounting**—Special mounting is required. Mount in vertical position only, filament end down. A clearance of at least 4 inches should be allowed between the bulb and any adjacent object. Connections to the filament and anode terminals should be flexible.

### Circuit Outputs:

Circuit Designation	Number of Tubes	Output Voltage		Load Current—DC Amps.	
		At 10 kv. Inverse Voltage	At 20 kv. Inverse Voltage	In-Phase Operation	Quadrature Operation
A	1	3000	6000	5	10
B	2	3000	6000	10	20
C	4	3000	6000	20	40
D	4	6000	12000	10	20
E	3	4500	9000	15	30
F	6	9000	18000	15	—
G	6	4000	8000	25	50
H	6	9000	18000	—	30
I	6	9000	18000	—	30

## 266C Vacuum Tube

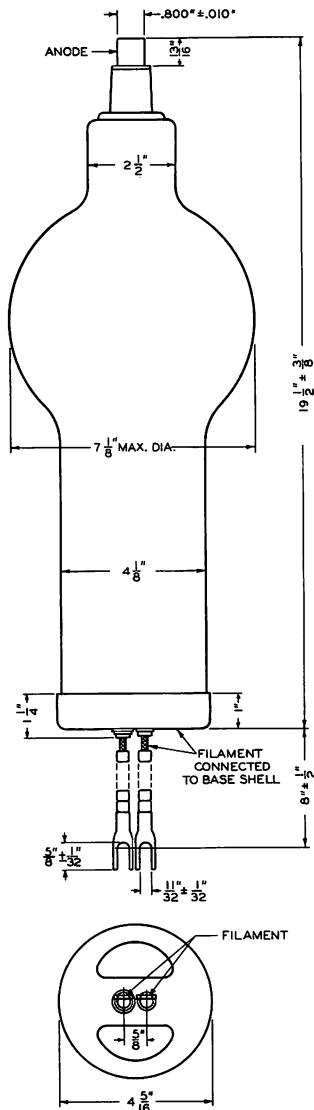
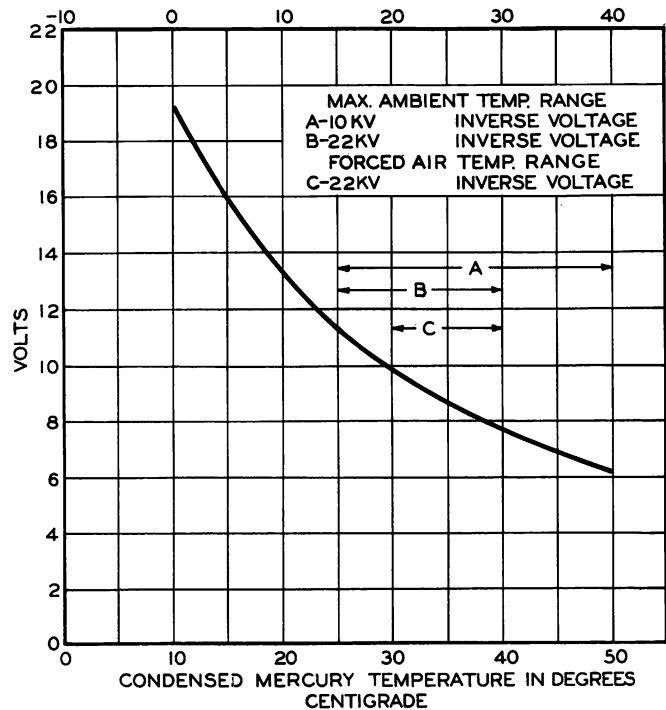

FIG. 1

### Ratings

Filament Voltage	5.0 volts
Nominal Current	42.0 amperes
Required Heating Time	300 seconds
Accelerated Filament Heating Recommended open circuit over-voltage	50%
Corresponding period of over-voltage application	30 ± 5 seconds
Tube Voltage Drop—Approximate	15 volts
Maximum Instantaneous Anode Current In-Phase Operation	20 amperes
Quadrature Operation	40 amperes
Maximum Average Anode Current In-Phase Operation	5 amperes
Quadrature Operation	10 amperes
Max. Time of Averaging Anode Current	60 seconds
Maximum Peak Inverse Anode Voltage at 15 to 30° C. ambient temperature	22 kilovolts
at 15 to 40° C. ambient temperature	10 kilovolts
at 30 to 40° C. forced air temperature	22 kilovolts

CORRESPONDING AMBIENT TEMPERATURE IN DEGREES CENTIGRADE AFTER TEMPERATURE EQUILIBRIUM



TUBE VOLTAGE DROP VS. TEMPERATURE FOR A TYPICAL TUBE

This is the temperature of the forced air applied to the bulb where the free mercury condenses. Approximately 5 cu. ft. per minute from a 1 inch nozzle and directed 1/2" above the filament base is recommended.

**Mounting**—Special mounting is required. Mount in vertical position only, filament end down. A clearance of at least 4 inches should be allowed between the bulb and any adjacent object. Connection to the anode terminal should be flexible.

### Circuit Outputs:

Circuit Designation	Number of Tubes	Output Voltage		Load Current—DC Amps.	
		At 10 kv. Inverse Voltage	At 22 kv. Inverse Voltage	In-Phase Operation	Quadrature Operation
A	1	3000	6500	5	10
B	2	3000	6500	10	20
C	4	3000	6500	20	40
D	4	6000	13000	10	20
E	3	4500	10000	15	30
F	6	9000	20000	15	—
G	6	4000	9000	25	50
H	6	9000	20000	—	30
I	6	9000	20000	—	30

## 267B and 319A Vacuum Tubes

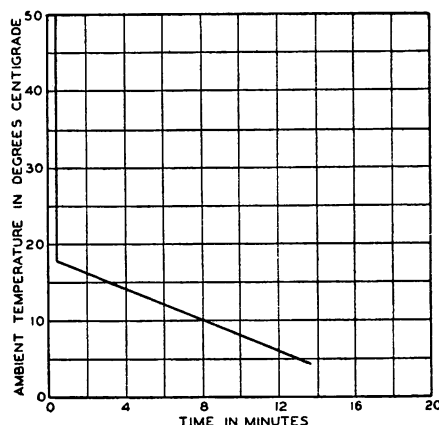
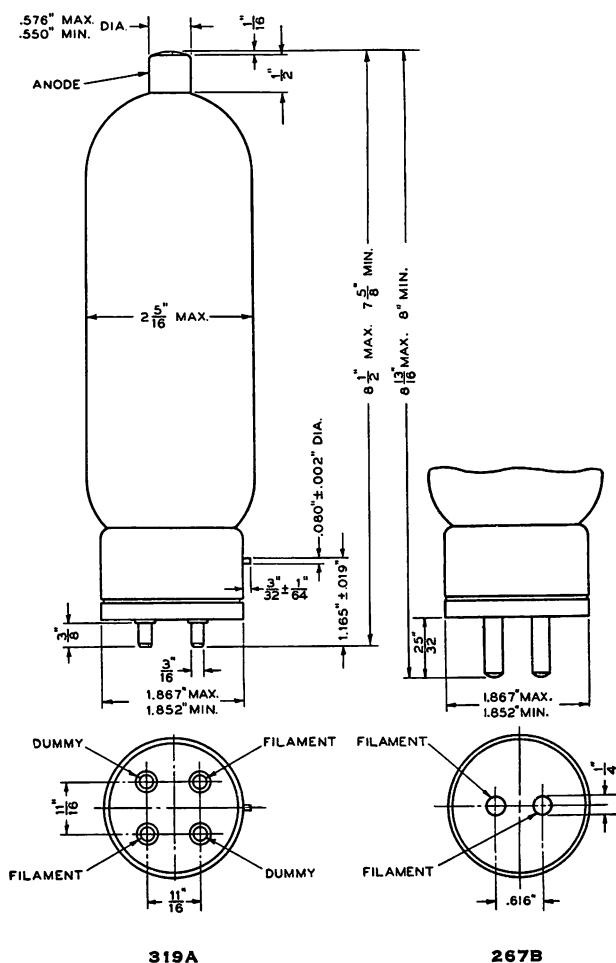

MINIMUM FILAMENT WARMING TIME VS. AMBIENT TEMPERATURE

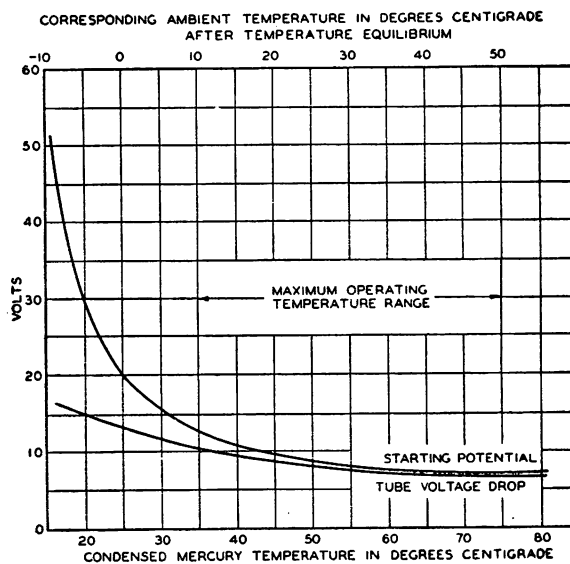

OPERATING CHARACTERISTICS FOR A TYPICAL TUBE

### Ratings

Filament Voltage	5.0 volts
Nominal Current	6.75 amperes
Required Heating Time	30 seconds
Accelerated Filament Heating Recommended open circuit over-voltage	50%
Corresponding period of over-voltage application	8 ± 2 seconds
Tube Voltage Drop—Approximate	10 volts
Maximum Instantaneous Anode Current	
In-Phase Operation	4 amperes
Quadrature Operation	8 amperes
Maximum Average Anode Current	
In-Phase Operation	1 ampere
Quadrature Operation	2 amperes
Max. Time of Averging Anode Current	15 seconds
Maximum Peak Inverse Anode Voltage	7.5 kilovolts
Maximum Ambient Temperature Range	10 to 50° C.

**Mounting**—The 267B tube requires a W. E. 138B, 139A or similar socket and the 319A tube a W. E. 148A or similar socket. A spring clip anode terminal connector is required. Mount in a vertical position only—base end down. A clearance of at least 2 inches should be allowed between the bulb and any adjacent object.

### Circuit Outputs:

Circuit Designation	Number of Tubes	Output Voltage At 7.5 kv. Inverse Voltage	Load Current—DC Amps.	
			In-Phase Operation	Quadrature Operation
A	1	2300	1	2
B	2	2300	2	4
C	4	2300	4	8
D	4	4600	2	4
E	3	3500	3	6
F	6	7000	3	—
G	6	3000	5	10
H	6	7000	—	6
I	6	7000	—	6

### 315A and 321A Vacuum Tubes

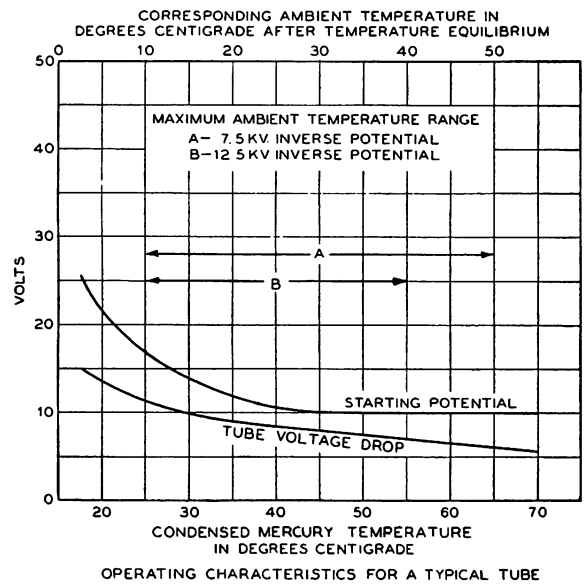
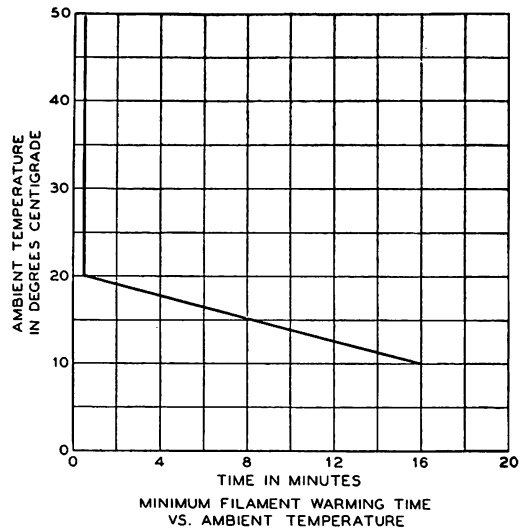
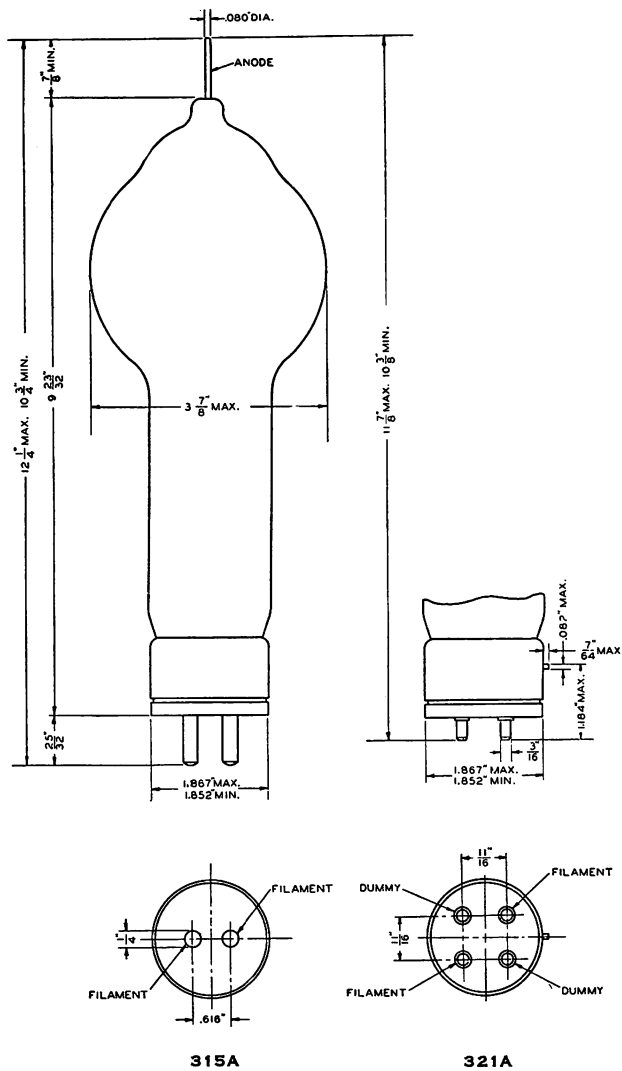

**Ratings**

Filament Voltage	5.0 volts
Nominal Current	10.0 amperes
Required Heating Time	30 seconds
Accelerated Filament Heating Recommended open circuit over-voltage	50%
Corresponding period of over-voltage application	15 ± 5 seconds
Tube Voltage Drop—Approximate	10 volts
Maximum Instantaneous Anode Current	
In-Phase Operation	4 amperes
Quadrature Operation	8 amperes
Maximum Average Anode Current	
In-Phase Operation	1 ampere
Quadrature Operation	2 amperes
Max. Time of Averaging Anode Current	15 seconds
Maximum Peak Inverse Anode Voltage	
at 10 to 40° C. ambient temperature	12.5 kilovolts
at 10 to 50° C. ambient temperature	7.5 kilovolts

**Mounting**—The 315A tube requires a 138B, 139A or similar socket and the 321A a W. E. 148A or similar socket. A special anode terminal connector is required. Mount in a vertical position only—base end down. A clearance of at least 3 inches should be allowed between the bulb and any adjacent object.

**Circuit Outputs:**

Circuit Designation	Number of Tubes	Output Voltage		Load Current—DC Amps.	
		At 7.5 kv. Inverse Voltage	At 12.5 kv. Inverse Voltage	In-Phase Operation	Quadrature Operation
A	1	2300	3800	1	2
B	2	2300	3800	2	4
C	4	2300	3800	4	8
D	4	4600	7600	2	4
E	3	3500	5800	3	6
F	6	7000	11500	3	—
G	6	3000	5000	5	10
H	6	7000	11500	—	6
I	6	7000	11500	—	6

***Western Electric***

**A development of Bell Telephone Laboratories, the research laboratories of the American Telephone and Telegraph Company and the Western Electric Company.**