

BELL TELEPHONE LABORATORIES,  
INCORPORATED

Schematic Circuit Diagram

6-26-33  
ISSUE: 1 I.K.  
7-6-33  
ISSUE: 2 I.K.  
2-2-34  
ISSUE: 3 R.J.T.  
5-16-34  
ISSUE: 4 I.K.

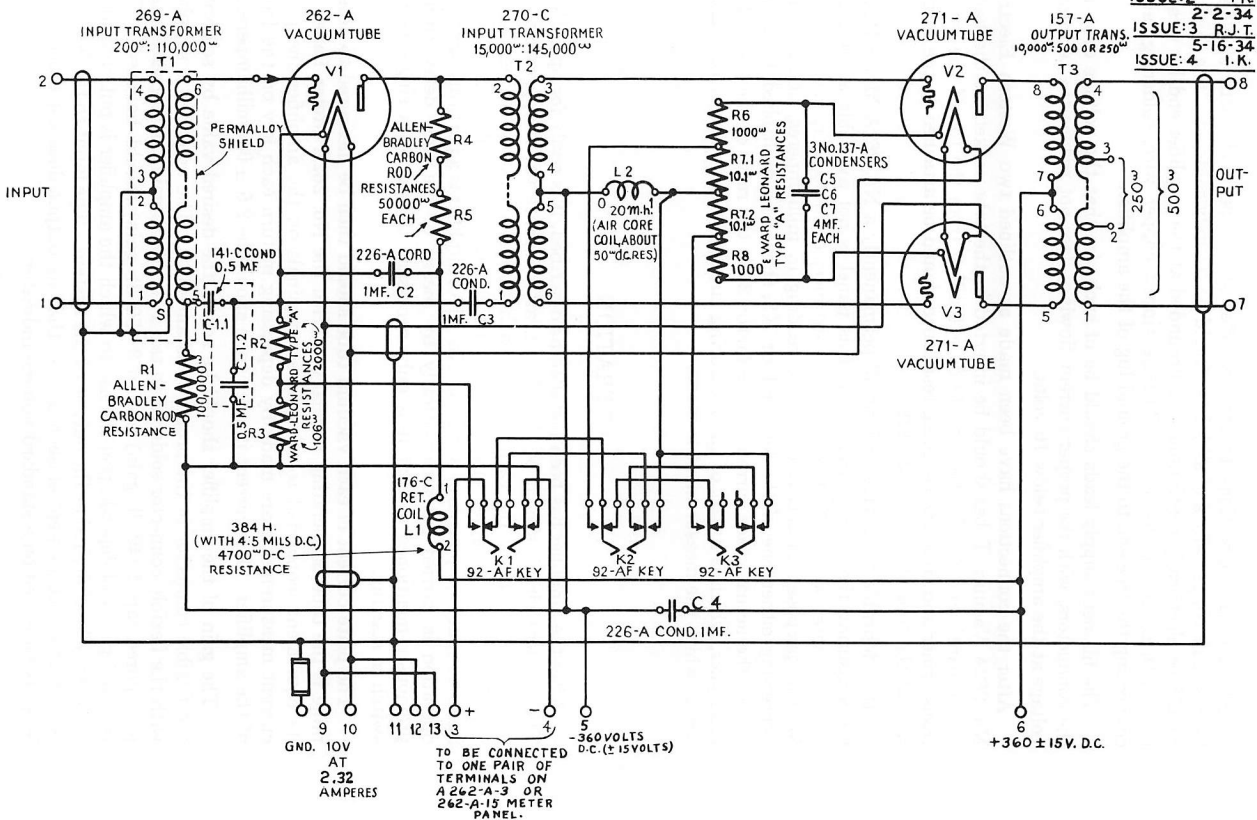

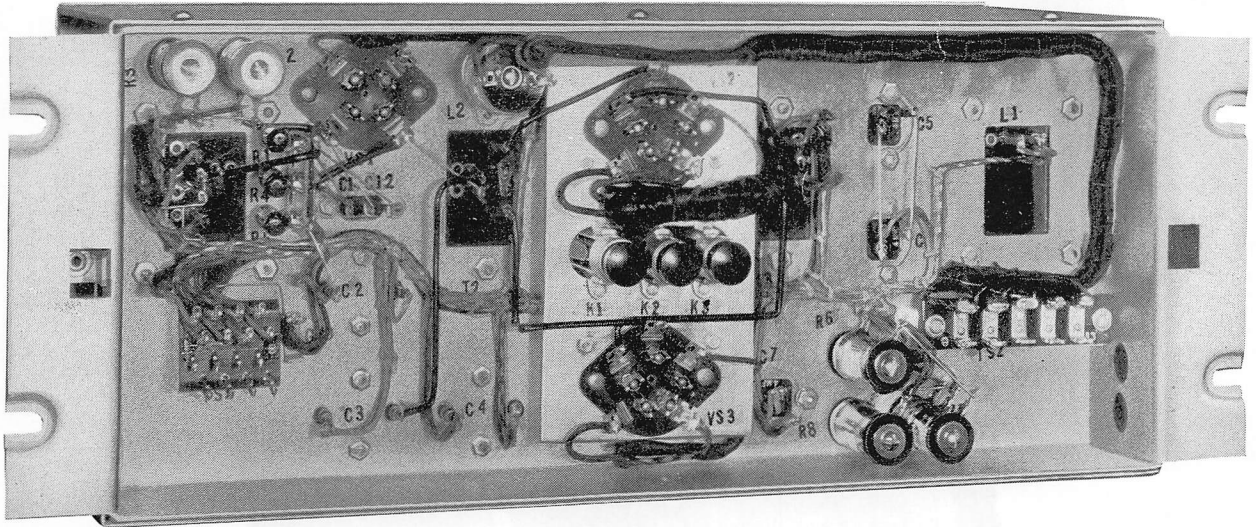

FRONT VIEW — MAT REMOVED

